

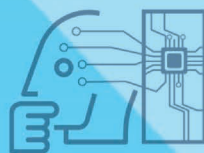

Compendium of Low Carbon Technology Innovations

Selected & Mentored under Low Carbon Technology Accelerator



Facility for Low Carbon Technology Deployment

DISCLAIMER

The document has been prepared to provide basic information about the project. The information has been compiled by Sangam Capital Advisors taking into consideration the information and the feedback received from the innovators and private stakeholders who were part of the programme.

The content and views expressed in this document are those of the contributors and do not necessarily reflect the views of BEE or UNIDO, its Secretariat, its Offices in India and elsewhere, or any of its Member States.

अभय बाकरे, आईआरएसईई
महानिदेशक

ABHAY BAKRE, IRSEE
Director General



ऊर्जा दक्षता ब्यूरो
(भारत सरकार, विद्युत मंत्रालय)

BUREAU OF ENERGY EFFICIENCY
(Government of India, Ministry of Power)



Message

The Government of India set up Bureau of Energy Efficiency (BEE) on 1st March 2002 under the provisions of the Energy Conservation Act, 2001. The mission of the Bureau of Energy Efficiency is to assist in developing policies and strategies with a thrust on self-regulation and market principles, within the overall framework of the Energy Conservation Act, 2001 with the primary objective of reducing energy intensity of the Indian economy. Some of the notable work includes Perform, Achieve and Trade (PAT) Scheme, Energy Conservation in the SMEs, Star labelling of appliances, Energy Conservation Building Codes (ECBC), and other Demand Side Management (DSM) initiatives to enhance energy efficiency.

In November 2021, India has laid claim on climate leadership by being the only large emerging economy to respond to the call for increased ambitions by announcing the goal to achieve NetZero emissions by 2070. Both renewable energy and energy efficiency are necessary for decarbonization efforts, innovation assumes a greater role to bring out low carbon technologies which present benefits such as reduction in greenhouse gas emissions, reducing demand for energy imports.

It is known that clean technology-based start-ups face various challenges in promoting their innovations in the market and therefore require mentoring, guidance, and financing support for commercial operations. It will help them to grow and sustain their businesses so that society in general and industrial and commercial sectors are benefitted.

With encouraging outcomes from the project Facility for Low Carbon Technology Deployment (FLCTD), the Bureau of Energy Efficiency is interested to see that the innovations are commercialized and adopted by the end-users.

I understand that in collaboration with the Government of India's Start-up India initiative, under the FLCTD project Sangam Ventures has completed four cohorts of the Accelerator programme which has identified, successfully trained and mentor 67 cleantech/climate tech start-ups. The training and mentoring support enable the start-ups to bring indigenously developed products and solutions to the market and provide tangible benefits while addressing the energy and environmental issues. These innovations help to advance the government's key initiatives such as "Start-up India", "Make in India", and assist the government to meet domestic and international commitments.

I would like to take this opportunity to congratulate all the winners and others who have successfully completed the accelerator programme and have commercialized their innovation

Abhay Bakre
(Abhay Bakre)
Director General.

स्वहित एवं राष्ट्रहित में ऊर्जा बचाएँ Save Energy for Benefit of Self and Nation

चौथा तल, सेवा भवन, आर.के.पुरम, नई दिल्ली-110 066 / 4th Floor, Sewa Bhawan, R.K. Puram, New Delhi-110 066

टेली / Tel.: 91 (11) 26178316 (सीधा / Direct) 26179699 (5 Lines) फैक्स / Fax: 91 (11) 26178328

ई-मेल / E-mail : dg-bee@nic.in, abhay.bakre@nic.in, वेबसाइट / Website : www.beeindia.gov.in



René Van Berkel
UNIDO Representative

UNIDO
Regional Office in India



Foreword

Over the past decades, the partnership between the Government of India and the United Nations Industrial Development Organization (UNIDO) has evolved to develop and improve the country's industry, energy and agriculture sectors. The adoption of the Sustainable Development Goals by the global community in 2015, specifically SDG9 (industry, infrastructure and innovation) entrusted UNIDO to assist India and its developing country member states with the transition towards Inclusive and Sustainable Industrial Development.

In 2016, UNIDO started, with the support of the Global Environment Facility, a project with the Bureau of Energy Efficiency (BEE), titled Facility for Low Carbon Technology Deployment (FLCTD). This aims to identify, demonstrate and validate innovative low-carbon technologies for application and commercialization in industrial, commercial and agriculture sectors. The project conducts innovation challenges in six technology areas and identifies the winning innovations which have a replication potential while delivering energy savings and emissions reduction. The winners receive financial support and industry-connect for field trials and independent validation while the subject experts provide mentoring support to improve the efficacy of the innovation. The FLCTD support aids the innovators to 'de-risk' their innovations before commercialization.

In 2019, FLCTD launched its Accelerator which provides mentoring to low-carbon technology start-ups and builds their capacity to take their innovations from laboratory to market. The Accelerator helped the development of the business plan and strategy for market entry, and in turn, prepared innovators to raise financing and also to access FLCTD support for technology validation.

India has joined the international community by committing to a zero carbon future. This will not be possible just with solutions that are already proven and feasible. Innovation in technology and production and consumption systems is necessary to achieve the necessary deep decarbonization across all sectors. Innovations in clean and low-carbon technologies and systems are required that are able to provide tangible benefits to end-users. Increased innovation and commercialization of innovative technologies will enable end-users to meet their own decarbonization targets and will encourage young entrepreneurs to develop low-carbon solutions.

The active interest taken by the Bureau of Energy Efficiency in the implementation of the FLCTD project demonstrates the Government of India's continued support of innovation and development of low-carbon technology solutions which will be required to meet the revised target of emissions intensity of India's GDP by 2030, and for the overarching sustainable energy transition.

This compendium reflects on the learnings of the starts-up in the four cohorts who received training and mentoring support from the Accelerator programme under FLCTD implemented by Sangam Capital Advisors Pvt. Ltd. It contains profiles of 67 low-carbon climate tech startups, many of which have already entered the market. Many of these innovations can also help to advance other Sustainable Development Goals.

(René Van Berkel)



Acknowledgement

The Low Carbon Technology Accelerator Programme - implemented by Sangam Capital Advisors is a part of Facility For Low Carbon Technology Deployment (FLCTD) project which is funded by Global Environment Facility (GEF), and jointly implemented by UNIDO and Bureau of Energy Efficiency (BEE).

We would like to express our profound gratitude to various stakeholders who have contributed towards developing this compendium by providing us with information, observations and suggestions.

Our special thanks goes to FLCTD Project Management Unit for guidance in implementation of the Accelerator programme.



Contents



Abbreviations and Acronyms
Executive Summary

Startups from the following sectors:

AI, ML, IoT & Deep Tech

Bigwig Automations	03
Citygen Technology	04
Cymbeline Innovations	05
Datamatrix Infotech	06
Impensus Electronics	07
Intech Harness	08
Irasus Technologies	09
LivNSenseTechnologies	10
Living things	11
Zodhya Technologies	12

Commercial & Residential Low GHG tech

Adyaha Ways	17
Ant Studio	18
Aproposdrive Technologies	19
Bodycast Innovators	20
Calvem Energy	21
Diffusion Coatech	22
Energy Recovery Solutions	23
Hivericks Technologies	24
Integrative Design solutions	25
IX Energy	26
Medcuore Medical Solutions	27
Newgen cleantech	28
Nettoyer Automotives	29

Panjurli Labs	30
Prayogik Technologies	31

Food & Agriculture

Agpharm Bioinnovations	35
Anguki Industries	36
Crop Domain Private Limited	37
Farm-Hand	38
Green Cross	39
Healventure Biosciences	40
Oscillo Machines	41
Pelican Thermogenics	42
Ruhvenile Technologies	43
Sand Bird	44
Saptakrishi Scientific	45
Satyukt Analytics	46
Tapah Mechatronics	47
Terracarb	48
Zerocircle	49

Industrial Low Carbon Technology

Aerostrovilos	53
AFECO	54
Birds Eye Energy	55
BluPower	56
BNG Spray Solutions	57
eGreen Compliance Consultants	58
Envoprotect	59
Exposome	60
Grassroots Energy	61
Torus Robotics	62
Ventragen	63

Resource Efficiency

Angirus Ind	67
Aria Aerotech	68
EcoOrbit AI Solutions	69

GreenTrek	70
Himalayan Hemp	71
Jivoule Biofuels	72
Malhari Projects	73
Revy-S	74
Svakalpan Engineering Designs	75
TGP Bioplastics	76
Uravu	77

Storage Technologies

Cancric	
MCS Cargar	81
MiniMines Cleantech Solutions	82
Offgrid Energy	83
Virya Batteries	84

Stakeholders	87
--------------	----

Abbreviations and Acronyms

AI	Artificial Intelligence
B2B	Business to Business
B2C	Business to Consumer
BIRAC	Biotechnology Industry Research Assistance Council
BLDC	Brushless DC motor
CAPEX	Capital Expenditures
CGAR	Compound Annual Growth Rate
CIN	Corporate Identification Number
DFM	Design for Manufacturability
DIPP	Department of Industrial Policy and Promotion
ESCo	Energy Service Company
EV	Electric Vehicle
FLCTD	Facility for Low Carbon Technology Deployment
FPC	Farmer Producer Companies
FPO	Farmer Producer Organization
GCIP	Global Cleantech Innovation Programme
GEF	Global Environment Facility
GHG	Greenhouse Gas
GOI	Government of India
GTM	Go-To-Market
ICE	Internal Combustion Engine
ICT	Information and Communication Technologies
IOT	Internet of Things
LDP	Low Density Polyethylene
MCA	Ministry of Corporate Affairs
ML	Machine Learning
MVP	Minimum Viable Product
NIESBUD	National Institute of Entrepreneurship and Small Business Development
OEM	Original Equipment Manufacturer
Opex	Operating Expenditure
POC	Proof of Concept
PV	Photo-voltaics
R&D	Research and Development
RE	Renewable Energy
ROI	Return on Investment
SME	Small and Medium Sized Enterprises
UNIDO	United Nations Industrial Development Organisation

Executive Summary



The Low Carbon Technology Accelerator programme, under Facility for Low Carbon Technology Deployment (FLCTD) - a project funded by the Global Environment Facility (GEF) and jointly implemented by United Nations Industrial Development Organization (UNIDO) and Bureau of Energy Efficiency (BEE) and was launched in 2019. The Accelerator is implemented by Sangam Capital Advisors Pvt. Ltd.

The Accelerator was designed to provide training and mentoring to startups with promising innovations who could not be shortlisted to the final round of the challenge as their application lacked understanding of the market and readiness of the innovation for commercialization.

The Accelerator focused on building 'softer' skills of the entrepreneurs and start-ups in the areas such as business model development, market segmentation, and financial projections. It helped participants to recognize and address critical barriers to the commercialization of their products while strengthening their intellectual property and technology portfolio.

The Accelerator has completed its fourth cohort in 2023 and has provided training and mentoring to 88 participants. The participants provided positive feedback on the programme content and design which has been found to be highly relevant to the needs of cleantech start-ups. The programme's emphasis on market research, business development, and financial modelling is considered valuable by the participants. Some entrepreneurs reported major, tangible results (investments, discovery of new markets) that would not have been attained if they hadn't participated in the programme.



The training sessions of the Accelerator were supplemented by the mentors, who coached the start-ups on various topics covered under the programme. The mentors were drawn from industry associations, financial institutions, winners of FLCTD Innovation Challenges, and individuals with long professional and business experience.

This compendium provides a brief introduction to each of the start-up that has successfully completed the training and mentoring provided under the Accelerator Programme. Information is organized as per their innovation category and is presented as a one-page information sheet which provides innovation summary, current status level of technology readiness, future plans, and contact information of the start-ups.

So far eleven start-ups from the Accelerator who completed the training were selected for the Annual Innovation Challenge of the FLCTD project is a testimony of the effectiveness of the Accelerator. These start-ups have received funding and industry connections to validate their innovation for commercial launch. These start-ups will bring forth potential solutions that can help the stakeholders to reduce the energy need and associated greenhouse gas emissions.

About Low Carbon Technology Accelerator

The Low Carbon Technology Accelerator programme has been designed to work with emerging cleantech start-ups through which the selected innovators are trained, mentored, introduced to potential investors, customers and partners. It thus helps start-ups “de-risk” their businesses and become market-ready to gain the confidence of potential clients and investors. Start-ups are then encouraged to apply to the FLCTD Innovation Challenge to avail further support to ‘de-risk’ their innovation and take it forward towards commercialization.

Three categories of applicants who brought promising technologies to the innovation challenge but could not be selected to the final round are:

- Entrepreneurs who already have an established presence in the market, but have not been able to make a dent in the cleantech/climate technology market;
- Start-ups and entrepreneurs without prior business experience;
- Start-ups and student-entrepreneurs/researchers with technologies at the ideation phase or only at the prototype stage in a laboratory.

It was envisaged that the start-ups could benefit from a business mentoring support programme such that their chances would improve in the future cycles of FLCTD Innovation Challenges.

The Accelerator Programme accepted applications in six categories, which are mentioned in the infographic below.



More than 75 stakeholders of the low carbon innovation ecosystem in the country were directly associated with the programme as mentors; screening committee members; judges; jury; and investors. Promotion and outreach activities were conducted in collaboration with Government of India organizations such as Startup India, AGNIi, Invest India, Office of the Principal Scientific Advisor. The programme design followed a 'customized support for each start-up' approach since each start-up was in a different stage of product development and commercialization. This kept the start-ups engaged in the various topics of training.

Key features of the program design are as follows:

- Workshops at the beginning, mid-term, and end of the programme – so that the cohort members, Sangam team, UNIDO team, mentors, investors, influencers and others can network and get to know each other.
- Weekly online webinars – interactive webinars delivered by specialists.
- Weekly post-webinar discussion sessions – organized each week after the webinar. This is specifically included to let the founders test their learnings while the programme is going on.
- Mentor-mentee calls – one-on-one calls with deep discussions around challenges faced by the start-up teams.

The alumni have always appreciated and acknowledged that mentoring is the most effective and they greatly valued the attention and guidance received on their business. Mentors have been selected based on their expertise in venture building and technologies relevant to the FLCTD theme – mentors from other UNIDO programs, FLCTD Innovation Challenge mentor pool and winners of the Innovation Challenge were also part of the mentor pool.

The mentors were mapped to a particular innovator depending on the mentor's expertise and mutual interest to set the top priorities for each innovator. Thus, each innovator had a chance to interact with multiple mentors and receive targeted inputs to overcome their business-building challenges. Using this customized support for each start-up, early stage cleantech entrepreneurs equipped with strong technical skills and impressive academic qualifications, were trained and mentored over a period of 4 months to develop a clear business strategy to avoid the common pitfalls which the start-ups otherwise are susceptible to.

The experts and mentors associated with the programme appreciated the programme as an opportunity to stay updated with the developments in the sector and scouted for curated opportunities for investments.

A total of 608 start-ups applied to the programme, out of which 88 start-ups were selected in the Acceleration Programme, out of which 67 clean-tech and agri-tech start-ups successfully completed and graduated out of the program.

The announcement of India's Net zero emissions goal and increased energy-intensity target from 35% to 45%, requires a number of technologies and business solutions to help the energy transition. Innovations such as those supported under the Accelerator for market launch will provide plausible solutions to the end-users to adopt clean / low-carbon technologies to lower energy consumption and reduce greenhouse gas emissions.

AI, ML, IoT & DEEP TECH





Bigwig Automations, Ahmedabad

Innovation: AI Device Synchronizing AC and Fan Control for Optimum Comfort and Energy Savings

Product Information

Bigwig Automations has developed an innovative AI-based air conditioning power saving device to provide optimum comfort to the users along with energy savings.

Category

AI, ML, IoT & Deep tech

Industry, Innovation Area

Electronics Power Saver & AI Devices

Patent/IPR

Pending

Startup Registration Information

Registered with DPIIT, Reg No: DIPP90525

SDG Goals

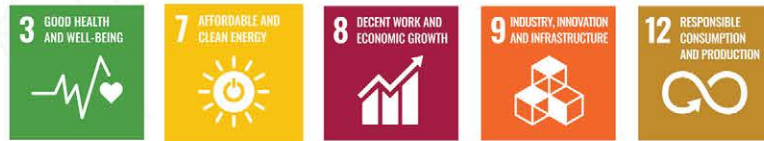

Competitive Advantage

Their AI-device is designed to provide comfort through unique algorithm which saves power and there is no compromise in user's comfort.

Market Penetration

The company aims to target existing AC users (residential, commercial and Government offices) and builders so the device can be offered as an additional USP with other amenities.

Growth Plans

- Building final product and brand awareness to the potential customers
- Pilot in multiple cities and states before going PAN India
- Continuous R&D for existing product development as well as new product development



BigWig IoT Device

Potential Customers

- Corporate Offices
- New AC Buyers
- Existing AC Users (Residential & Commercial)
- Government Offices and Educational Institutes

About the Company

Bigwig Automations is a green technology and clean-tech start-up with the objective of developing affordable, energy efficient, easy to use future ready products to improve quality of life.

About the Founder

Rahul Sheth is a graduate from Rajasthan Technical University, Kota and has been working in the electronics industry from the last 10 years.

Contact Information

✉ bigwigautomations@gmail.com

☎ +91-8866666755

🌐 www.bigwigauto.com



Citygen Technology, Jhansi

Innovation: Digitizing Waste Supply Chain for Municipalities

Product Information

Citygen has developed a full stack waste management operating system to bring data driven accountability for all the stakeholders i.e 4000+ urban local bodies, 256 M+ urban households, 6M+ ragpickers, 30K+ recyclers, and 1M+ brand owners.

Category

AI, ML, IoT & Deep Tech

Industry, Innovation Area

Waste Management Supply Chain

Patent/IPR

Patent Application Number:
202211003971

Startup Registration Information

Registered with DPIIT, Reg No: DIPP 85804
Udayam Registration No: UDAYAM- UP-39-0007116

SDG Goals



Competitive Advantage

Full stack integration across the waste value chain increases the overall waste collection efficiency.

Market Penetration

GTM strategy is to first plug the problem of urban local body by deploying Citygen Lite Model through public private partnerships which we have developed through our channel partners.

Growth Plans

- Build the final prototype and conducting pilot testing across urban local bodies
- Expanding to 20 urban local bodies in Jharkhand throughout public private partnerships in the next one year
- Manufacturing the hardware device with a sample of 100 units and deploying across all the urban local bodies



Wearable Hardware for Waste Segregation

Potential Customers

- Urban Local Bodies
- Banking Partners
- Kabadiwallahs
- Recyclers
- Consultancy Projects

About the Company

Citygen technology is a waste management company which acts as a technology enabler for the complete waste management ecosystem.

About the Founder

Saurabh Kumar and Kapil Suhane are the co- founders. They are both graduates from IIT and ISM Dhanbad. Saurabh has been working with waste management sector for the past 5 years and Kapil prior to building his entrepreneurial journey, was working with Schlumberger.

Contact Information

✉ citygenerp@gmail.com

☎ 8009544907

🌐 <https://home.citygen.in/home>
[https://www.linkedin.com/
Citygen-Technology](https://www.linkedin.com/Citygen-Technology)



Cymbeline Innovations, Bengaluru

Innovation: Tracking and Reducing Emissions for Smart Cities, Industries and Public Spaces

Product Information

Cymbeline has developed IoT solutions that accelerate the automotive OEMs and smart cities to digitally transform and make data driven decisions to be energy efficient and environmentally safe.

Category

AI, ML, IoT & Deep Tech

Industry, Innovation Area

Energy and Pollution Monitoring, IIOT

Patent/IPR

Trademark applied

Startup Registration Information

Registered with DPIIT, Reg No: DIPP6068

SDG Goals



Pollution and energy Monitoring Device

Competitive Advantage

Their solution is Plug and Play which integrates into the existing system with no downtime.

Market Penetration

The company has sixteen paying customers which include leaders in Automotive Manufacturing, Auto Lighting, Glass and two Fortune 500 companies and four Fortune India 500 Companies.

Potential Customers

- Automotive OEMs
- Tier I Automotive Suppliers
- Smart City Corporations

Growth Plans

- Scale to at least five Industrial clusters in the next year
- Start operations in the Middle East and US market in the next two-three years

About the Company

An Industrial IoT Company building connected, sustainable solutions, tracking and reducing emissions for smart cities, industries and public spaces. Reduction of hyper-local pollution and energy monitoring through deep analytics to derive source of pollution, understand energy needs and propose clean energy alternatives.

About the Founder

Vivek V Gowripeddi is an Msc in Electrical, Electronics and Communications Engineering from IIIT - Bangalore with experience in Project Management for DRDO. Pavan has a Master's degree from BITS Pilani and is the CTO of the company.

Contact Information

✉ vivek@cymbelinein.com

☎ +91 98868 36524

🌐 <https://cymbelinein.com>

🌐 <https://www.linkedin.com/company/cymbelinein>

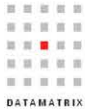

Datamatrix Infotech, Pune

Innovation: Technology Platform to optimize Energy & Water usage

Product Information

Datamatrix is a technology platform for remote monitoring, audit and optimization of energy, water management and asset performance. The technology is built on Digital Twins and AI. It can drastically bring down the cost of instrumentation with significantly enhanced capabilities for improved performance.

Category

AI, ML, IoT & Deep Tech

Industry, Innovation Area

Industrial, Energy & Water Efficiency

Patent/IPR

Patent No: 236496

Startup Registration Information

Registered with DPIIT, Reg No: DIPP28358

SDG Goals



Dashboard for Pump Performance Monitoring

Competitive Advantage

The technology can be remotely deployed across a wide spectrum of industries ranging from manufacturing industries, utilities, agriculture & commercial buildings, at a fraction of the conventional technology cost. The technology platform will help to remotely manage engineering services for industrial utilities.

Potential Customers

- Automobile Companies
- Government Bodies
- Real Estate
- IT Companies

Market Penetration

Technology Readiness Level (TRL) – 9.
Technology is being scaled up.

Growth Plans

- Platform delivery service centre at Kochi
- Setup office at Toronto
- Fund raising for commercialisation

About the Company

A comprehensive technology platform for sustainable energy & water management.

About the Founder

R. Thomas is an electrical engineer with over 25 years of experience in large energy and water projects.

Contact Information

✉ thomas@datamatrixinfotech.com

☎ +91-9527956959

🌐 <http://datamatrixinfotech.com>

🌐 <https://in.linkedin.com/in/thomas-raphel-094a6523>

Innovation: Post Harvest Storage Solutions for Fruits & Vegetables

Product Information

IMPact Fresh – an automated filter-based solution for cold storage that not only controls temperature and humidity but also analyses the respiration and hormonal activity of the commodity and controls the gas concentration inside the cold room to elongate its shelf life.

Category

AI, ML, IoT & Deep Tech

Industry, Innovation Area

Agri - tech

Patent/IPR

N/A

Startup Registration Information

Registered with DPIIT, Reg No: DIPP29102

SDG Goals



Competitive Advantage

Unlike conventional storage solutions which only monitors and controls temperature and humidity, IMPact fresh goes a step further to monitor and control parameters like ethylene, carbon dioxide, ammonia and oxygen that helps to preserve the freshness of the commodity and increase its shelf life.

Market Penetration

Impensus has installed systems in Tamil Nadu and Bangalore for farmer producing organizations and direct-to-home grocery suppliers. The company has also exported the systems to Egypt and Qatar.

Growth Plans

- Provide solutions to reduce wastage for fruits & vegetables in transit, then for dairy and meat industry
- Finally, provide end – to – end storage solution for all commodities across the globe



Smart Controller

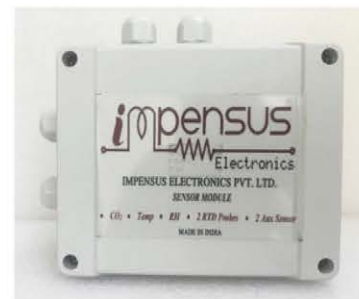

Integrated Sensor Module

Potential Customers

- Cold storage & warehouses
- Grocery delivery companies
- FPOs

About the Company

Impensus Electronics provide technologically driven modular solutions for post-harvest processes. With the plug-and-play modular approach, the company decentralizes storage infrastructure and elongates the shelf life of the stored items by 1.5 to 2 times.

About the Founder

- a) Dinesh Narayanan, B.E. with 8 years of experience in the post-harvest sector.
- b) Guru Vignesh V, Electrical & Electronics Engineer and MBA graduate with experience in KPO, and Agri Tech industries.

Contact Information

✉ dinesh.n@impensuselectronics.com

☎ +91 72085 46859

🌐 www.impensuselectronics.com

🌐 <https://www.linkedin.com/in/company/impensuselectronics>



Intech Harness, Pune

Innovation: IoT Enabled, Farmer Obedient Pump Controller

Product Information

For farmers facing erratic power & water conditions, this controller automates farm irrigation with an ability to respond to power & water disruption without human intervention, unlike GSM-based controllers.

Category

AI, ML, IoT & Deep Tech

Industry, Innovation Area

Agri-tech Irrigation

Patent/IPR

Patent No: 309927

Startup Registration Information

Registered with DPIIT, Reg No: DIPP25257

SDG Goals



Competitive Advantage

- The product does not require any human intervention and has the ability to cover up the lost time and respond to disruptions on its own
- The uniqueness of the product is its simplicity. People tend to confuse it with the existing auto starters (lower end of the spectrum) and GSM based controllers that require human intervention

Market Penetration

- The company has signed up 2 dealership agreements with FPO's
- Completed 2 technical evaluations with 2 pump OEMs
- Selected by Afro Asian Rural Development Organisation for accelerating the technology to 30 African nations
- 2 LOI from Agri-tech IoT firms for last-mile delivery of the irrigation schedule



Jalaparayah Autotech Pump Controller

Potential Customers

The end user is the farmer and the company is acquiring new customer through FPO's.

Growth Plans

- Scale-up inventory for sale
- Increase the dealerships
- Fund Raising for scaling
- Hiring the right team
- Streamlining of operations

About the Company

Intech Harness Pvt Ltd is an Agri-tech irrigation company offering a combination of hardware and IoT services. They have developed a solution that addresses the current issues in farm irrigation and handholding the farmer into the future through the modular offering of digital agriculture.

About the Founder

- Tarang Patel , Co-founder & CEO with 27 years of experience in sales & marketing.
- Priya Patel, Co-founder - Technical with 17 years of experience in electronics industry.

Contact Information

✉ tarang@intechharness.com

☎ +91-9823112346

🌐 <http://www.intechharness.com>

🌐 <https://www.linkedin.com/in/tarang-patel-42075b21/>



IRASUS

Irasus Technologies, Gurgaon

Innovation: Digital twins for Solar PV and Battery Storage

Product Information

Irasus has launched its flagship product Preksha™. A platform for creating digital twins of physical infrastructure namely solar PV and battery storage. The platform enables data visualization, data analytics and software services.

Category

AI, ML, IoT & Deep Tech

Industry, Innovation Area

Data Analytics For Clean Energy Generation, Storage And Consumption

Patent/IPR

N/A

Company Registration Information

CIN Number: U74999DL2018PTC339203

SDG Goals



Competitive Advantage

Irasus is quite modular in terms of the product offering and the benefits for customers begin right at this level. Preksha™ helps to understand the cell & battery pack behavior and the platform builds predictive models that helps to understand more about the battery.

Market Penetration

Technology Readiness Level (TRL) – 6.
Prototype (Minimum Viable Product) ready at a low level.

Growth Plans

- Scale the current assembly set-up from 150 to 6000 batteries under management
- Increase the amount of processing of batteries from 200 to 500 per month

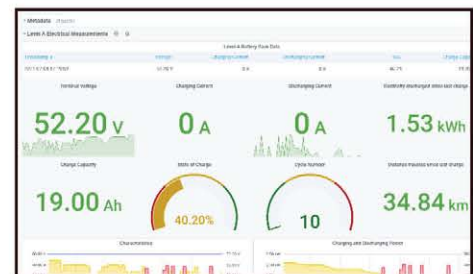
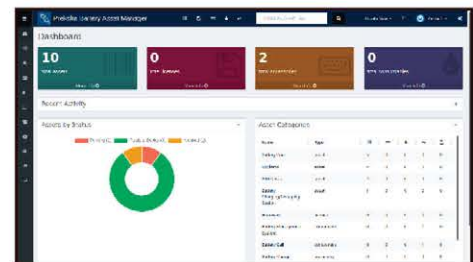

Dashboard for Battery Performance monitoring

Potential Customers

- Battery Storage Companies
- EV manufacturing units

About the Company

Irasus innovation is a data infrastructure for clean-tech equipment and modular analytical software offering built for acquiring & consuming electricity data to augment the safety, reliability, durability & affordability of low-carbon technologies.

About the Founder

- Arjun Sinha Roy, MSc (Hons) in Mechanical Engineer & Economics, BITS Pilani.
- Anirudh Ramesh, B.E. in Electrical & Electronics Engineering, BITS Pilani.

Contact Information

✉ anirudh@irasus.com

☎ +917737486223

🌐 www.irasus.com

🌐 linkedin.com/in/anirudh-ramesh-0



LivNSense Technologies, Bengaluru

Innovation: Decarbonizing the Manufacturing Sector using Real Time Energy Balancing AI

Product Information

GreenOps is a technology platform that provides real-time energy balancing by creating digital twins and harnessing the power of artificial intelligence to decarbonize the manufacturing sector.

Category

AI, ML, IoT & Deep Tech

Industry, Innovation Area

Manufacturing

Patent/IPR

Greenops™

Company Registration Information

CIN NUMBER: U72900KA2018PTC11028

SDG Goals



GreenOPS - Real time SAAS Energy Balance Platform

Competitive Advantage

- Plug and play platform for heterogeneous process data acquisition
- ROI of 20-25%
- Real time predictive actionable insights for rapid response
- Unified digital view of plant operations in real time
- Cloud agnostic platform to improve operational bottom-line and reduce emissions

Potential Customers

- Chemical Mfg Plant in US
- Petrochemical Plants in India, US
- AL Smelters in India
- API Mfg. Companies in India

Market Penetration

Presently, paid pilots are being conducted with 5 customers in India and abroad. With a revenue of US\$ 400k in 2020, the company is looking to target both national and international markets.

Growth Plans

The company is planning revenue target of the following:

- FY22: \$3M
- FY26: \$81M

About the Company

LivNSense is a pioneering industrial AI platform venture that aims at maximizing the profitability of the process manufacturing industry with key focus on process efficiency, energy optimization and GHG reductions.

GreenOps™ is a Digital Twins platform that enables cognitive functions for a cleaner, optimized and streamlined production process to create the factory of the future.

About the Founder

Mr. Avnish Kumar, ounder and CEO with 25+ years experience in the engineering and information technology (IT) industry. He is an alumnus of NIT-Durgapur and MBA from University of Melbourne.

Contact Information

✉ contact@livnsense.com

☎ 91 98451 61339

🌐 www.livnsense.com

🌐 <https://www.linkedin.com/company/livnsense-technologiespvt-ltd>



Living Things, Mumbai

Innovation: Retrofit for Airconditioners to improve efficiency by 15%

Product Information

Living Things Aircon helps to save a minimum of 15% on split/window air conditioners' energy consumption. The product can be retrofitted easily on the external side of the AC unit that displays the energy usage of the unit.

Category

AI, MT, IoT & Deep tech

Industry, Innovation Area

An IoT Platform to save energy consumption

Patent/IPR

Yet to file Patent for our Proprietary Algorithm

Startup Registration Information

Registered with DPIIT, Reg No: DIPP42687

SDG Goals



Living Things Aircon Module

Competitive Advantage

The product improves the air conditioning efficiency by 15% than 5 star rated air conditioners. It doesn't compromise on human comfort. Living Things is compatible with any brand, make or model of the ACs. It provides real-time quantified data to validate energy savings through active / inactive energy modes.

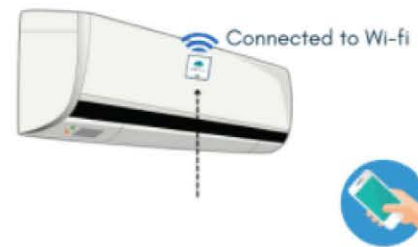

Aircon Module Fitted on the top of the AC

Market Penetration

Currently installed 150+ devices on ground for over 35 customers. Pipeline of 3,500 devices to be installed over the next 12 months. Technology is at pilot demonstration stage.

Potential Customers

- Chemical Fertilizers
- Glass Industry
- Government Bodies
- PSUs

Growth Plans

- Dashboard improvement as per customer usecase
- Quality Testing Certification
- Patent to be filed
- Scale to 10,000 units in next 18 months to achieve Product Market fit

About the Company

Living Things is a SINE IIT Bombay incubated company with a mission to save on split/window AC's energy consumption to reduce carbon emissions.

About the Founder

- Madhusudhan Naik, a VNIT Nagpur Alumnus, 2017, in Electronics and Communications Engineering with prior experience of 3 years in an IoT startup.
- Salil Rana, a VNIT Nagpur Alumnus, 2016, in Electrical Engineering, has 5 years of experience in Marketing.

Contact Information

✉ madhusudhan.naik@icapotech.com

☎ +91 - 8459517743

🌐 <https://livingthings.in/>

🌐 <https://www.linkedin.com/in/madhusudhan-naik/>



Zodhya Technologies, Hyderabad

Innovation: AI-based Hardware Device Reducing Energy Consumption of HVAC Systems

Product Information

Zodhya is developing a technology which is a combination of hardware (Saver) and software (Soul) solution:

- Saver - Reduces the energy consumption for HVAC systems with an AI-based algorithm on the backend.
- Soul - Online dashboard monitoring for the energy usage enabling the client to foresee inefficiencies, repair and connects to renewables based on usage.

Category

AI, MT, IoT & Deep tech

Industry, Innovation Area

Energy efficiency & management

Patent/IPR

Application number: 202241002297

Startup Registration Information

Registered with DPIIT, Reg No: DIPP9137

SDG Goals



Competitive Advantage

Full-stack integration for the client on how to source, manage and consume energy. It offers upto 30% savings on energy bills.

Market Penetration

The company aims to approach conglomerate clients who run chains and have buildings as part of their business and demonstrate value for a single location to begin with and then implement the solutions for their entire chain.

Growth Plans

- Building an upgraded version of the 'Saver' which can address wide variety of clients and their spaces
- Relevant certifications and validation for wider acceptance
- Deploying pilots in the target sectors in the next quarter



Zodhya IoT Device

Potential Customers

- Chain of Spaces - Offices, Retail, Hospitality
- Facility Management Providers
- Service Providers - Architects, Builders, Real-Estate

About the Company

Zodhya is developing an AI-based solution which improves the way of sourcing and utilisation of energy thus reducing carbon emissions. The devices have been helping the commercial buildings and spaces in reducing their energy bills by 30% and optimizes their energy usage.

About the Founder

Rohith Pallerla is the Co-founder and the CEO of Zodhya. He has done his B.Tech in Chemical Engineering from IIT - Madras.

Contact Information

✉ contact@zodhyatech.com

☎ +91-7981580576

🌐 www.zodhyatech.com

COMMERCIAL AND RESIDENTIAL LOW GHG TECH





Adyaha Ways, Hyderabad

Innovation: Ceiling Fan based on Induction and BLDC Motor

Product Information

Highly efficient ceiling fan with low power consumption. We have conducted two tests successfully at the NABL Lab Hyderabad for both BLDC and Induction Motor:

1. SUKOI BLDC motor ceiling fan has been tested with 20.91W, AD=220 m³/min, Service Value = 10.52

2. SUKOI Induction motor ceiling fan has been tested with 33.8W, AD=222 m³/min, Service Value = 6.57

Category

Commercial and Residential Low GHG Tech

Industry, Innovation Area

Ceiling Fan

Patent/IPR

Patent Application Number:
366503-001 (Design Patent),
202211039731 (Utility Patent)

Company Registration Information

Registered with DPIIT, Reg No: DIPP65220

SDG Goals



Competitive Advantage

- 5 Star Energy efficiency, aerodynamic design
- 35% cheaper as compared to similar fans
- 54% reduction in energy consumption
- 21 months simple payback period
- Purely Indigenous technology

Market Penetration

The company aims to position themselves with the growing BLDC fan market using their high efficiency technology.

Growth Plans

- Opportunity to replace existing 500 million fans. Energy saved – 60 BU, cost savings - \$3.3B/annum, Peak demand reduction 14000 MW, Annual CO₂ emission reduction potential-43 MtCO₂. Addressable market size – 500M USD
- Opportunity to sell 40 million fans through the freedom to choose 5-star rated product. Serviceable market, 40M USD



SUKOI:BLDC Fan

Potential Customers

- Large institutions
- Power distribution companies
- Low-income families through Government subsidies

About the Company

Adyaha designs sustainable solutions for Indian and Global markets. Working on energy efficiency to develop sustainable electrical appliances. Energy Efficient appliances lead to savings in energy consumed, reduction in peak demand and reduction in CO₂ emissions.

About the Founder

Sunil Kumar Maurya, an Aeronautical Engineer from the Aeronautical Society of India has over 7 Years of experience in DRDO working on UAVs, Helicopters and Missile technologies. he started Adyaha Ways Pvt Ltd in 2019, centering on Research and Development of electrical appliances, and is based in Hyderabad.

Contact Information

✉ sunilmaurya@adyahaways.in

☎ +91-9494926970

🌐 <http://www.adyahaways.in/>



Ant Studio, New Delhi

Innovation: Evaporative Natural Air Cooling Structure for Outdoors

Product Information

Beehive is a natural cooling system that is made of natural materials like terracotta and uses evaporative cooling instead of CFCs. It is a more sustainable alternative to air cooling, especially for outdoor areas. Also the products are locally handmade, which helps in creating employment.

Category

Commercial and Residential Low GHG Tech

Industry, Innovation Area

HVAC, Evaporative Cooling

Patent/IPR

N/A

Company Registration Information

CIN Number: LLP - AAI - 4731

SDG Goals



Competitive Advantage

The cooling systems are using minimal plastic for production, promoting eco-friendly materials for construction like terracotta. No CFCs are used for cooling, causing negligible harm to the atmosphere. The system is customizable as well as aesthetic and has decorative value.

Market Penetration

The product is at Technology Readiness Level (TRL) 9. The system was installed and tested successfully by a few customers. It has been demonstrated to cool effectively at a few exhibitions and sites.

Growth Plans

- Standardization and mass production of Beehive
- Make product smarter and efficient
- Develop a smaller cooling system (Ether)
- Generate funds for new product development and launch



Beehive: Natural Air Conditioner for outdoors

Potential Customers

- Cafes
- Restaurants
- Farmhouses (outdoor cooling)
- Residencies

About the Company

ANT Studio is an organization working in the intersection of art, nature, and technology. Currently working on providing novel architectural solutions and developing sustainable cooling systems based on terracotta, while engaging with local craftsmen.

About the Founder

- Monish Siripurapu, B.Arch, SPA Delhi, PG Diploma in Robotic Fabrication at IAAC, Barcelona
- Brahmi Kavuri, Master of Information Systems from Carnegie Mellon University Experienced Product Manager

Contact Information

✉ monish.siripurapu@ant.studio

☎ +91-9953330270

🌐 <http://www.coolant.co/>

🌐 <https://www.linkedin.com/in/monish-kumar-80072740/>

Innovation: Energy Efficient, Magnet Free SRM Technology for Ceiling Fans

Product Information

Aproposdrive has successfully realized low wattage switched reluctance motor (SRM) technology-based ceiling fan which consumes only 35 watts compared to 75 watts of a conventional ceiling fan. It saves more than 50% of energy at all speeds. The SRM motor is a rare earth permanent magnet free, indigenous technology, that mitigates inherent motor noise, and it is easy to manufacture.

Category

Commercial and Residential Low GHG Tech

Industry, Innovation Area

Electric Motor Drives

Patent/IPR

Patent Granted, No: 331672

Startup Registration Information

Registered with DPIIT, Reg No: DIPP11533

SDG Goals



Competitive Advantage

The company has developed its efficient SR motor for ceiling fans globally. The company can solve key challenges like power density, inherent motor noise & complex control. Compared to BLDC motor-based fans, this motor is completely magnet-free & easy to manufacture.



SRM technology for ceiling fans

Market Penetration

The product is at TRL 7. Prototype (Minimum Viable Product) is ready. Pilot validation was done at IIT Bombay. Currently the company is working with a manufacturing partner for pilot assembly line.

Potential Customers

- Ceiling fan companies
- Consumer appliance companies
- Motor drive companies.

Growth Plans

- Collaboration with industry partners
- Reach TRL 9 through various pilot deployments
- Fund raising for scaling up

About the Company

Aproposdrive Technologies is a motor technology company that designs motor architecture & develops electronic controller solutions. The company also develops core energy-efficient technology for consumer appliance and e-mobility industry.

About the Founder

- Dr. Saurabh Nikam, M.Tech + Ph.D. in Electric Machines from IIT Bombay leads Motor Development
- Nimish Kothari, M.Tech in Power Electronics from IIT Bombay leads Electronic Development.

Contact Information

- ✉ nimish@aproposdrive.com
- ☎ +91-7709216928
- 🌐 <http://www.aproposdrive.com/>
- 🌐 <https://www.linkedin.com/in/nimish-kothari/>

= FOXTINI Bodycast Innovators, New Delhi

Innovation: Energy Efficient Axial Flux Motors and Pumps

Product Information

Foxtini has developed energy efficient, compact, light and low-cost Axial Flux Motors and Pumps made of soft magnetic composite. Owing to its light weight and compact form factor, this motor finds use in Solar Pumps, DC Inverter AC compressor, Electric Vehicles and other Variable Speed Appliances. Besides the high performance, the motor also offers significant reduction (up to 50%) in the use of rare earth metals.

Category

Commercial and Residential Low GHG Tech

Industry, Innovation Area

High efficiency, low-cost, Eco-Friendly Axial Flux Solar Pumps

Patent/IPR

Patent pending

Startup Registration Information

Registered with DPIIT, Reg No: DIPP80619

SDG Goals



Competitive Advantage

Their highly efficient (>90% less and compact) motors have higher Mean Time Between Failures (MTBF) which result in low wear and tear. Their motors are Eco Friendly and low in cost as they are made using 50% less rare earth metals.

Market Penetration

- B2B Motor Sales as an OEM Supplier
- Customised motor design and manufacturing contracts
- Royalties for Licensing the technology
- B2C Distribution channel development

Growth Plans

In the next one year, their target is to diversify the application of their motors for:

- Home Appliances: 250 W-700 W motor with one OEM
- Solar Water Pumps: 2 HP / 7.5 HP
- eBicycle Retrofitting Kits: 250 W
- Electric Two Wheelers



SMC based Axial Flux Motor

Potential Customers

- Electrical Appliance OEMs
- eMobility
- Industrial Tool Manufacturers/Conveyer Systems

About the Company

FOXTINI is an Indian motor design and manufacturing company. This motor finds most apt use in the Variable Speed Applications and is made using upto 50% lesser rare metals.

About the Founder

Amit and Roopak are the Co-founders. They have over 25 years of experience, each bringing together skills in innovation & management. Amit is an Engineer by education and passion and Roopak is a technology management professional with a graduation in science and PG in management.

Contact Information

✉ info@foxtini.com

☎ +91 9810126666

🌐 www.foxtini.com



Calvem Energy, New Delhi

Innovation: Minimization of Rare Earth Metal Based Magnets in Electric Motors

Product Information

Calvem Energy has developed a range of traction motors for L5 category Electric three-wheelers and high-performance Electric two-wheelers, covering a power range from 3 kW to 8 kW. Designed for Indian driving conditions, the in-house developed traction motors, coupled with intelligent controllers, offer high efficiency (>90% combined), high torque density, and low torque ripple.

Category

Commercial and Residential Low GHG Tech

Industry, Innovation Area

Electric mobility, Motors and controllers for Electric vehicle propulsion

Patent/IPR

Patent Granted, No: 202211003435

Startup Registration Information

Registered with DPIIT, Reg No: DIPP78754

SDG Goals



Competitive Advantage

- The motor and controller solution is compact and the control algorithm offers the best dynamic performance required for EVs reducing the use of rare earth metals by upto 50%
- Solutions catering to light weight EV's in the Indian context improving cost efficiency, electromagnetic shielding and product life and reliability



Product Prototype

Market Penetration

- GTM strategy is to enter the market with motor and controller solution for electric three-wheelers and two-wheelers
- Expanding to other segments as a B2B OEM supplier

Potential Customers

- Electric vehicle manufacturers
- Aftermarket (through distributors & retailers)
- Markets other than Electric vehicles like Industrial motors, pumps etc.

Growth Plans

- Start trial production of motors (~ 100 units/month) from Feb-March 2023 and commencement of pilot testing by deploying the product in multiple vehicles across the Delhi region
- Fundraising for setting up a manufacturing facility to scale production as per the market demands

About the Company

Calvem Energy is an IIT Delhi incubated startup developing motors and controllers for electric vehicle propulsion with a goal of making motors and their control units more efficient, compact and reliable through innovations in Electromagnetic Design, Power Electronics Design and Motor Control Algorithms.

About the Founder

Anurag Sharma has done Masters from Manipal University and currently pursuing PhD from IIT Delhi (ctd.), He has more than five years of industry experience with Luminous and L&T. Akashdeep Singh, Alumnus of Jadhawpur University. He has more than three years of industry experience with Luminous.

Contact Information

✉ anurag@calvemenergy.com

☎ +91-8448281136

🌐 www.calvemcontrols.com



Diffuson Coatech, Chennai

Innovation: High Temp. Resistant Low Friction Diffusion Coating for Corrosive and Acidic Environments

Product Information

MetaBoid is a reactive diffusion technology that can provide high hardness of over 1700 HV and a low friction coefficient. MetaBoid is highly wearing resistant even at high temperatures in abrasive and corrosive environments. MetaBoid is up to 50x superior compared to processes like nitriding and carburizing.

Category

Commercial and Residential Low GHG Tech

Industry, Innovation Area

Mechanical, Materials, Surface Engineering

Patent/IPR

N/A

Startup Registration Information

Registered with DPIIT, Reg No: DIPP57276

SDG Goals



Competitive Advantage

MetaBoid can provide the highest wear protection compared to any commercially available coating in its market. MetaBoid protects products from abrasion even at high temperatures and corrosive acidic environments. Diffuson's technology can perform 20% longer than (HVOF WC) material and costs less by 40%. MetaBoid offers a high production rate and flexible batch sizes.

Market Penetration

The product is at TRL 7. Prototype (Minimum Viable Product) is ready. Pilot validation was done with industrial customer. Currently working with the food & beverages industries of Gujarat for pre-commercial deployments.

Growth Plans

- Set up large scale manufacturing plant
- Acquire additional customers
- Fund raising for commercialization



Hardness & friction measurement of MetaBoid

About the Company

Diffuson Coatech is a manufacturer of high-performance surface protection coatings for OEMs who wants to enhance the durability of machine elements.

About the Founder

- Mr. Atul is an M.S. graduate in surface engineering with 4 years of industrial R&D experience.
- Mr. Chandra Shekar is a Mechanical Engineer with 20+ years of experience in domestic and foreign manufacturing industries.

Contact Information

✉ d.Coatech@gmail.com

☎ +91-7397 296915

🌐 www.diffusoncoatech.blogspot.com

ENRECOVER Energy Recovery Solutions, Pune

Innovation: Low Grade Waste Heat to Electricity Solutions for the Industry

Product Information

Enrecover system helps to recover the industrial/geothermal un-used or waste heat at a lower temp (700°C to 2500°C) and converts into electricity. It is a binary system in which the waste heat from the source(temp 700°C to 2500°C) is extracted by the fluid and is allowed to expand through a radial outflow

Category

Commercial and Residential Low GHG Tech

Industry, Innovation Area

Manufacturing (Energy)

Patent/IPR

Patent Application No: 20202101889

Startup Registration Information

Registered with DPIIT, Reg No: DIPP4810

SDG Goals



Competitive Advantage

Enrecover's innovation in Turbo genset (Radial outflow) and cost effectiveness in overall technology, meets international standards. Enrecover also offers modular (50 kW), cost effective and customer centric solutions.



ERP system for power generation

Market Penetration

The product is at TRL 7. MVP is completed. Pilot validation done with Industrial customer. Currently working with dairy, pharmaceutical, steel & paper industries in India for commercial deployments.

Potential Customers

- Geothermal industries
- Marine & steel industries
- Chemical refineries
- Petrochemical industries
- Tyre & rubber, Pharmaceutical, Paper & pulp, distilleries, etc.

Growth Plans

- Targeting OPEX (BOOT) model for expansion
- Set up a fully automatic manufacturing & testing facility
- Fund raising for intensive R&D and ESCO Model

About the Company

Enrecover technology generates clean electricity through waste heat & pressure sources from the geothermal and industrial waste sources by using binary fluids and optimum system. It helps to reduce carbon emission from the environment which enables industries to gain carbon credit.

About the Founder

- Abhijeet Chaudhari (M. Tech in Energy from VIT University, Vellore).
- Prajyot Singh Bisen (M. Tech in Power Electronics from VIT University, Vellore).
- Sagar Shelot (M.B.A in Marketing)
- Nikhil Chougale ((M. Tech in Energy from VIT University, Vellore).

Contact Information

✉ nikhil.c@enrecover.com

☎ +91- 9975 2773 57

🌐 <http://www.Enrecover.com>

🌐 <https://www.linkedin.com/in/nikhil-chougale-01a59582/>

HIVERICKS Hivericks Technologies, Chennai

Innovation: Battery Protection and Green Charging Solutions for Li-Ion Devices

Product Information

XOPTIMUS solutions offer a range of hardware to suit every customer's need, whether charging at office, home or while driving. The products ensure safe and optimal charging which saves energy and increases the life expectancy and performance of the device's battery.

Category

Commercial and Residential Low GHG Tech

Industry, Innovation Area

Battery charging, IOT, IoT, AI/ML, Consumer electronics

Patent/IPR

Patent Application No: 201941035496

Startup Registration Information

Registered with DPIIT, Reg No: DIP27229

SDG Goals



Competitive Advantage

- Universally compatible
- AI based battery intelligence for near real-time charging

Market Penetration

The company aims to focus primarily on:

- Influencer and Community marketing
- Social Media Advertising through LinkedIn to target a particular customer segments

Growth Plans

- Initial launch in market place and pilot with corporates or OEMs
- Expanding business across India by selling 10 lakhs hardware units in first 2-3 yrs
- Global expansion and exploring other use case like EV charging

About the Company

Hivericks is building AI enabled, intelligent, cleantech charging solutions for Li-Ion devices like laptops, phones that will make chargers smarter, creating unique charge programs to protect the battery while reducing individual carbon footprint by 38%.

About the Founder

Hemalatha has over 18 years of experience working in MNCs like Ford, TCS, JDA, Pepsi. Arun and Govind have over 7 years of experience in IoT Product development and deployment.



XOPTIMUS

Potential Customers

- Delivery Partners
- Cab Operators
- IT Corporations
- OEM Vehicle Manufacturers

Contact Information

 hema.r@hivericks.com

 +91- 91768 31334

 www.xoptimus.in



Integrative Design Solutions, New Delhi

Innovation: IoT solutions for optimising Building Energy Resources

Product Information

ISEE is an IOT based operational energy efficiency solution, using machine learning & artificial Intelligence based controls for the optimization of energy resources in buildings. ISEE-Opta is an on-field cloud-based controller which is supported by a software platform.

Startup Registration Information

Registered with DPIIT, Reg No: DIPP44200

SDG Goals



Competitive Advantage

ISEE provides instant intelligence on the building energy through field sensor devices and helps reduce the building energy consumption by 10- 35% using on-field cloud-based controllers. Unlike competitors, ISEE uses Building Energy Twin (BET) for predicting accurate energy-saving actions. ISEE aims to 0.2 MnT-CO2 emission reduction in the next 5 years.

Market Penetration

The product is at TRL 6. Prototype (Minimum Viable Product) ready. Pilot validation done with UN Office building, New Delhi. Currently working with shopping malls and retail stores for installations.

Growth Plans

- Set up field devices manufacturing unit
- Reach TRL 9 through large scale pilot deployments in commercial buildings
- Fund raising for commercialization

About the Company

IDSPL is a cleantech start-up working on the development of innovative products and processes to augment sustainability and human comfort in the built environment. This is done through the development and deployment of innovative and cutting-edge scalable solutions to address energy,

About the Founder

- a) Kanagaraj Ganesan, 13+ years experience in building energy efficiency sector
- b) Roopa Nair, 12+ years experience in architectural design.

Category

Commercial and Residential Low GHG Tech

Industry, Innovation Area

Built environment, IOT & AI

Patent/IPR

N/A

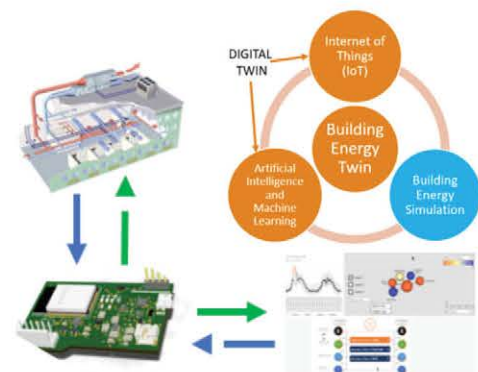

Cycle of buiding energy twin

Potential Customers

- Hospitals
- Hotels
- Airports
- IT parks
- Shopping malls
- Retail stores.

Contact Information

- ✉ kanagaraj@ids-pl.com
- ☎ +91-9971841354
- 🌐 <http://www.i2l.net> <https://>

- 🌐 www.linkedin.com/in/kanagaraj-g-62b2a512



IX Energy, Noida

Innovation: Converting Existing HEV to Partial/Full electric

Product Information

The kit converts existing vehicles into hybrid electric or battery electric. The kit can be installed on to diesel/CNG vehicles of any make. The kit has been certified at ICAT and improves fuel economy by 25%. The two products are Electric Synergy Drive (ESD) for partial electrification and Electric Energy Drive (EED) for full electrification.

Category

Commercial and Residential Low GHG Tech

Industry, Innovation Area

Automotive, E-mobility

Patent/IPR

N/A

Startup Registration Information

Registered with DPIIT, Reg No: DIPP14169

SDG Goals

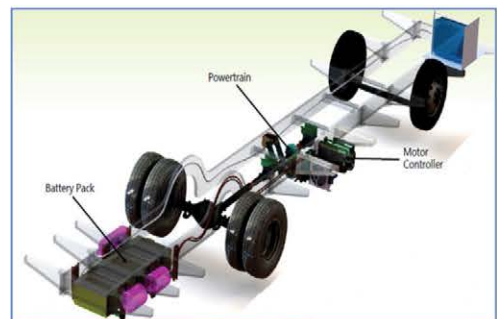

Electric Synergy Drive System

Competitive Advantage

- Most competition has moved towards full electrification
- IX Energy is one of the only ones in the heavy commercial vehicle category
- Unlike other solutions, IX kit is removable and the vehicle can be restored back if and when needed allowing the kit to be used for a new vehicle base

Potential Customers

- State transport corporations
- Private fleet operators
- Logistics companies.

Market Penetration

The product is at TRL 7. Prototype (Minimum Viable Product) ready and certified with ICAT. Pilot validation is in progress with customers.

Growth Plans

- Scale our current assembly setup
- Scale deployment with fleet owners
- Increase tech and sales team

About the Company

IX energy converts conventional heavy ICE vehicles into hybrid or fully electric vehicles through kits that are commercially viable allowing faster adoption of electric vehicles on Indian roads.

About the Founder

Anshu Dewan, Bachelor's in Electrical Engineering from Illinois Tech, Chicago, MSc. in Computer Science from the University of Chicago. He has over 23 years of experience in software, sales & business development.

Contact Information

✉ info@ixenergy.in

☎ +91-8126 174 491

🌐 <http://www.ixenergy.in>

🌐 <https://in.linkedin.com/company/ix-energy-private-limited>

Innovation: Eco-Friendly Alternative to Tackle Indoor Air Pollution

Product Information

Medcuore has designed a Bio-degradable AI-IoT based Air Quality Monitoring system. Their Air Purifier has eco-centric advanced anti-microbial nano-particulate carbon-metallic ion seven stage filter with photocatalytic oxidation technology.

Category

Commercial and Residential Low GHG Tech

Industry, Innovation Area

Smart Air Quality Monitoring and Purification

Patent/IPR

Patent Application No(s): 202141015495

Startup Registration Information

Registered with DPIIT, Reg No: DIPP61388

SDG Goals



Competitive Advantage

Low cost, smart, eco-friendly and self sustainable solution as compared to commercially available products.

Market Penetration

The company aims to target:

- Tier 1 & 2 cities via dealership and distributon model
- Product promotion via tenders and government departments

Growth Plans

They plan to establish experience centres in tier 1 and 2 cities along with online and offline store to promote sales.



PuroCare eco+ air purifier

Potential Customers

- Residential Apartments
- Co-Working Spaces
- Entertainment and Recreational Hubs

About the Company

MedCuore is a MedTech company which aims to reduce and manage indoor air pollution through sustainable technology solutions.

About the Founder

Paul Pradeep J, has over 6 years of experience in the Medical Device Industry. He is a Masters in Biomaterials and Biomechanics from Politecnico di Milano, Italy.

Contact Information

✉ support@medcuore.com

☎ +91-9360583390

🌐 www.medcuore.com

🌐 <https://www.linkedin.com/company/medcuoreindia>

Innovation: Thermal Energy Storage & Delivery System for Cooling Commercial Building

Product Information

NewGen COOL (NGC) is a patent-pending hydrate technology in which proprietary solution changes phase to ice-like compounds and releases heat. NGC utilizes this phenomenon to produce and store a chilled slurry during off-peak hours for thermal energy storage (TES). NGC slurry is then utilized during peak hours to deliver the desired cooling in commercial buildings.

SDG Goals



Competitive Advantage

Newgen COOL can store 4x energy vs chilled water at 7-100°C, unlike other TES systems, can flow to deliver the cooling across building. NGC slurry consumes 50 % less pumping power, and can increase building efficiency up to 30 %, and save 50% CAPEX for new installations. The potential to mitigate CO2 in next 5 years is up to 35,000 Mnt.

Market Penetration

The product is at TRL 6. Prototype (Minimum Viable Product) ready. Pilot validation was completed with an urban farming partner for 2 RT systems.

Growth Plans

- Commercial scale pilot deployment to increase TRL > 8
- System integration with building management system for wider commercialization
- Fund raising for commercialization

About the Company

NewGen COOL is a technology initially developed by NewGen Gas Pvt. Ltd. A National University of Singapore spin-off, NewGen Cleantech - the Indian Subsidiary, is currently seeking pilot collaborators.

About the Founder

- Dr. Maninder Khurana, Ph.D. in Chemical Engineer, Management of Tech., Black Belt LSS
- Prof. Linga (NUS), Hydrate technology expert, > 18 years R&D.

Category

Commercial and Residential Low GHG Tech

Industry, Innovation Area

Commercial, Process Engineering

Patent/IPR

Patent Application No(s): WO2020117129A1, 10202013036T

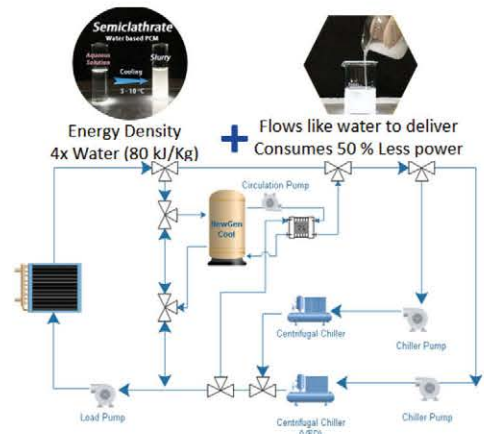

Thermal Energy Storage & Delivery (TES+D)

Potential Customers

- IT parks
- Office buildings
- Shopping malls
- Hotels
- CA buildings.

Contact Information

✉ maninderkhurana@newgengas.com

☎ +65-83948175

🌐 <http://www.newgengas.com/>

🌐 <https://www.linkedin.com/in/maninder-khurana-74601615>



Nettoyer Automotives, Pune

Innovation: Hybrid Electric Retrofit kit for Two Wheelers

Product Information

The company has developed a hybrid electric retrofitting kit which can convert a conventional petrol engine scooter into a plug in hybrid electric vehicle. By using the technology, users can reduce the cost of operation by 90% and reduce the emissions emitted from the vehicle by 72.46%. The user can travel on electricity as well as on petrol whenever they are out of electricity.

Category

Commercial and Residential Low GHG Tech

Industry, Innovation Area

Automotive Powertrain Design, Hybrid electric

Patent/IPR

Patent pending.

Startup Registration Information

Registered with DPIIT, Reg No: DIPP43610

SDG Goals



PHEV Kit and Motor controller with wiring connection

Competitive Advantage

This technology eliminates the worry of range anxiety on the vehicle. It is unique, economical and saves cost of travelling by using a hybrid (electric + petrol) powertrain on the same vehicle.

Potential Customers

- Vehicle OEMs
- Last mile delivery and fleet operators
- Sales executives and traders

Market Penetration

The product is at TRL 5. The company has completed 25 paid pilots projects with customers. Currently, the company plans to develop an optimized design of motors to provide high efficiency and performance.

Growth Plans

- Development of optimized designs by computer-aided engineering analysis
- Development of dyes
- Development of testing facility
- Initiating sales

About the Company

The company develops hybrid electric and full electric powertrain systems for vehicles.

Contact Information

✉ nettoyerautomotives@gmail.com

☎ 9834830928

🌐 nettoyerautomotives.in

🌐 <https://www.linkedin.com/company/nettoyerautomotives/>

About the Founder

Ravindra Joshi, completed his B.E. in Mechanical Engineering, He has a prior experience in developing P3 and P4 based powertrains for two wheelers, three wheelers and four wheelers.

Innovation: Portable Dust Collector for Construction Sites

Product Information

The Dust Collector is a portable device, capable of purifying air in construction sites. The device uses thin film air filtration technology to trap construction dust. 85% of escaped raw materials can be recovered and can be reused using materials retention system in the device.

Category

Commercial and Residential Low GHG Tech

Industry, Innovation Area

Air Pollution Control, Dust Collectors

Patent/IPR

Patent pending.

Startup Registration Information

Registered with DPIIT, Reg No: DIPP89129

SDG Goals



Competitive Advantage

- Thin film filters developed by Panjurli Labs never clog during operations and have a self-cleaning mechanism.
- The device consumes 40 W power, requires less maintenance and is customizable as per the needs of the customer.

Market Penetration

The product is at TRL 5. They have completed the prototype in the month of January of 2022 and currently are working on the MVP.

Growth Plans

- MVP of dust collector
- R&D of indoor and outdoor air purifier
- Clean room and clean air ecosystem
- Dust collector for other segments
- HVAC and IAC filters



Dust Collector

Potential Customers

- Construction companies
- Civil contractors
- Renovation contractors
- Interior decorators

About the Company

Panjurli Labs is a startup aiming to reduce global air pollution levels using newly invented thin film air filtration technology.

About the Founder

Ashik S V, TEDx speaker, an automobile engineering graduate from Bangalore has invented a patent pending thin film air filtration technology. His invention has been published in more than 20 media articles. Winner of Climathon 2021.

Contact Information

✉ panjurllabs@gmail.com

☎ +91 9900270875

🌐 www.panjurllabs.com

🌐 <https://www.linkedin.com/company/panjurli-labs>



Prayogik Technologies, Bhopal

Innovation: Thermoelectric Module Static generator for converting Heat Energy to Electricity

Product Information

TMSG is a highly reliable remote power supply unit working with natural gas or propane. TMSG generates electrical power by converting heat energy directly into electricity. It does not contain moving parts, has an extremely long lifetime, and requires minimal service.

Category

Commercial and Residential Low GHG Tech

Industry, Innovation Area

Industrial, Military Services, Oil and Gas

Patent/IPR

Patent Application No(s):
E- 106/545/2018/MUM

Startup Registration Information

Registered with DPIIT, Reg No: DIPP36732

SDG Goals



Competitive Advantage

- More efficient (9%) as compared to existing solutions
- Specially designed TMSG-DC in concern with Indian weather (High Humidity, Warmer Country +50 deg, Rain, Storm)
- Smaller in size, weight and No separate GCS(Gas Conditioning System) in TMSG –DC
- Commercially 40% cheaper than existing competing products

Market Penetration

The company has successfully tested the product TMSG-DC-200 at Siachen Indian Army Base Camp for military purposes which we want to expand to US military services as well including the Oil & Gas Market.

Growth Plans

- Set up large scale manufacturing plant
- Large scale pilot deployment with industrial clients
- Fund raising for commercialization



Thermoelectric module static generator (TMSG-DC-200)

Potential Customers

- Defence Sector
- Oil and Gas Industry

About the Company

M/s Prayogik Technologies is working towards power management solutions and has partners like GAIL India which has supported them in field pilot in oil & gas for cathodic protection of pipelines.

About the Founder

Mr. Vijay Mamtani MBA in Oil & Gas from UPES Dehradun and B.Tech in electrical engineering from MANIT Bhopal.

Contact Information

✉ vijay@prayogik.in

☎ +91-7045573807

🌐 <http://www.prayogik.in/>

🌐 <https://www.linkedin.com/in/vijay-mamtani-44b636150/>

FOOD AND AGRICULTURE



Innovation: Bio-Based Shelf-Life Enhancer for Reducing Post Harvest Loss

Product Information

Agpharm Bioinnovations has developed a novel microbial bioformulation, which is maximizing the post-harvest shelf life of fruits and vegetables (F&V) by creating a modular atmosphere in the F&V storage container thus reducing microbial decay and deterioration.

Category

Food and Agriculture

Industry, Innovation Area

Agri-Biotech, Industrial Biotechnology

Patent/IPR

Patent Application No. 202011041628

Startup Registration Information

Registered with DPIIT, Reg No: DIPP34172

SDG Goals



Competitive Advantage

A novel bioformulation that drastically reduces the post harvest wastage and loss of F&V by 30-40%. It can extend the post-harvest shelf life by 1-3 weeks. Unlike expensive, hazardous chemical-based interventions, the novel bioformulation (VOLAFRESH™) is sterile, non-residual, eco-friendly, cost-effective, end-user-friendly. It has the potential to mitigate 5000 Mnt CO2 in next 5 years.

Market Penetration

The product is at Technology Readiness Level (TRL) 4. The product is ready for pilot trials with farmers and corporate clients to reach its MVP for commercialization.

Growth Plans

- To achieve TRL7
- Piloting with different stakeholders and simultaneously explore strategic partners for large scale manufacturing and licensing.

About the Company

A biotech start-up providing affordable biotechnology-based solutions in the area of agriculture, food and health. The company's portfolio entails cost effective products to enhance the post-harvest shelf life of grains, fruits and vegetables from farm to fork.

About the Founder

Dr. Sanjai Saxena, M.Sc. In Biological Sciences, Ph.D. in Biotechnology, 20+ years leadership experience in the interface of Biotechnology and Pharma.



Novel Bioformulation



Delivery as a sachet / pad (similar to tea bag)

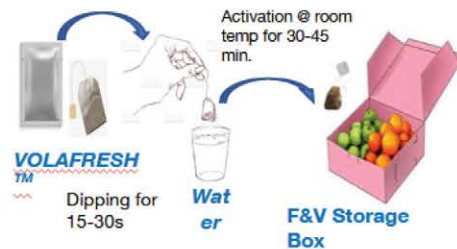

Microbial bioformulation for maximizing shelf life of fruits and vegetables

Potential Customers

- B2C and B2B players in agri business Supply Chain
- Government organizations and cooperatives
- NGOs

Contact Information

✉ sanjaisaxena@agpharmbioinnovations.com

☎ +91 9888 219815

🌐 <https://www.agpharmbioinnovations.com>

🌐 <https://www.linkedin.com/in/sanjai72saxena/>



Anguki Industries, Dimapur

Innovation: Banana Fibre-based Composite Furniture and Engineering Composite Materials

Product Information

Anguki Industries manufactures composite furniture and engineering materials from wasted banana pseudo-stem alongside a sustainable livelihood model.

Startup Registration Information

Registered with DPIIT, Reg No: DIPP83453

SDG Goals



Competitive Advantage

Waste to wealth products satisfy the three pillars of sustainable development:

- Economy
- Social
- Environment

Market Penetration

Anguki Industries shall launch the products in the local cellular level throughout Northeast India as pilots.

Growth Plans

- Develop infrastructure for testing and manufacturing
- Deployment of pilot projects for relevant industries, setting up sustainable livelihood model for adopted villages and creating a chain of handicraft based sustainable utility products

Category

Food and Agriculture

Industry, Innovation Area

Waste to wealth from wasted banana pseudo stem to superior Engineering materials.

Patent/IPR

N/A



Demonstration of banana pseudo-stem composite stool strength

Potential Customers

- Furniture Industries (Damro, Godrej etc)
- Engineering Industries (Oil and Gas, Structural Engineering)

About the Company

Anguki industries is one of the first Green Technology start-ups of Northeast India, converting waste banana pseudo-stem into composite furniture and engineering composite materials.

About the Founder

Kapil Thapa has done Masters in Manufacturing Engineering with experience in Industry, Research and Development and Academia. Tovi Chopi is an Entrepreneur and a Social Worker with over 15 years of business experience.

Contact Information

✉ kapilthapaofficial@gmail.com

☎ +91 9789941718

🌐 <https://www.linkedin.com/in/kapil-thapa-2444b11b2?original-Subdomain=in>



Crop Domain, Bengaluru

Innovation: Microbial Solutions to Reduce Insect & Pest attack

Product Information

Crop Domain has developed novel strains of the bacterium which are proved to be highly effective against agriculturally important insect pests. They have developed innovative cutting-edge solutions using new knowledge of the root-associated micro biome to create novel products.

Category

Food and Agriculture

Industry, Innovation Area

Agribiotech; Industrial Biotechnology

Patent/IPR

N/A

Company Registration Information

CIN Number: U74999KA2017PTC102649

SDG Goals



Competitive Advantage

- Continuous innovations create the next wave of bio agricultural products via discovery and development of biopesticides as well as combination products to overcome growing pest resistance and active ingredient dosage issues.
- Fast and accurate – eliminates pests within 48 to 72 hours
- Cost effective – 60% reduction in pest management costs
- Biodiversity restoration and conservation

Market Penetration

The product is at TRL 7. Pilot scale demonstration of the technology (100 L or 100 Kg Scale) and technology demonstration in an actual environment is done.



Fermenter setup for the microbial production

Potential Customers

- Smallholder farmers, organic crop growers, urban farming community
- Seed industries, nurseries & agriculture research institutions.

Growth Plans

- Certifications - CIBR & International
- Set up a large-scale manufacturing plant
- Reach TRL 9 through large scale pilot deployment with industrial clients
- Fund raising for certifications, commercialization and global expansion

About the Company

A bio-tech start-up working with a vision to unlock the secrets of the root microbiome of immortal plants, thus increasing farm productivity through innovative, cutting-edge and cost-effective solutions.

About the Founder

- Dr. Mahadeva, 12 years of experience in Industry & Research Institute exploring molecular biology, protein engineering, DNA barcoding and microbial biotechnology.
- Lavanya, 11 years of experience in industrial biotechnology.

Contact Information

✉ hmswamy@cropdomain.com

☎ +91-9686597766

🌐 <http://www.cropdomain.com/>

🌐 <https://www.linkedin.com/in/dr-mahadeva-swamy-h-m-72b93b41/>



Farm-Hand, Bengaluru

Innovation: Farm Digitizing Solutions for Connecting Farming Organizations

Product Information

The Farm-Hand Platform democratizes farm digitization and solution connectivity for farming organizations. The platform is a data-driven farm survey/management and agri-solution marketplace platform, allowing farming organizations to digitize and manage their farmers and filter market solutions based on farm characteristics and operation needs.

Category

Food and Agriculture

Industry, Innovation Area

Agri., E-commerce, Data Analytics

Patent/IPR

International Patent No:
PCT/EP2020/082742

Company Registration Information

CIN Number: U72900KA2020FTC135445

SDG Goals



Competitive Advantage

Farm-Hand Platform provides a one-stop farm data management visualization platform for the aggregator and uses forecasting and community review approach to increase transparency, trust & quality control in selecting agri-tech solutions & services.

Market Penetration

Farm-Hand Platform is at TRL 7 and pilots are currently being conducted. Farm-Hand has agreements for 1000+ farms and is working with 5+ agri-solution companies for platform integration.

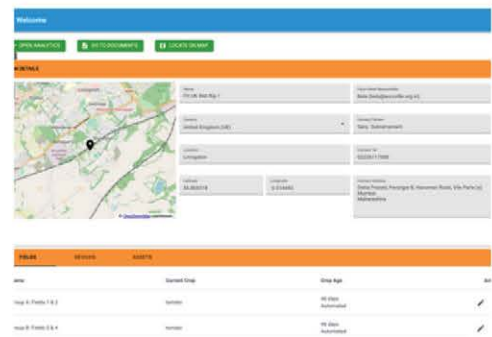

Dashboard for farm management system

Potential Customers

Farming aggregators growing high-value crops in Karnataka, Gujarat, Tamil Nadu and Andhra Pradesh and agri-solution companies.

Growth Plans

- Reach TRL 9 of the Farm-Hand Platform
- Integrate 40 agri-solutions onto the platform
- Fundraising for commercialization and scale-up with partners

About the Company

Farm-Hand is an agri-tech solution provider, turned solution broker. The company has also developed Water-Hand (TRL 9, focusing on crop specific precision irrigation). To accelerate the transition to sustainable and productive farming practices, farming organizations and farmers, the company is focusing on an ecosystem approach.

About the Founder

- Abhimanyu Bhargava (MA Hons), Development Economist
- Dr. Andrew Peacock (Ph.D.) – Domain expert in the energy system and irrigation modeling.

Contact Information

✉ Abhi.b@farm-hand.in

☎ +44-7449317499

🌐 www.farm-hand.in

🌐 <https://www.linkedin.com/company/farm-hand-ltd/>

Innovation: Multipurpose Waste Decomposer to stop Stubble Burning

Product Information

Green Cross Agritech has developed a multipurpose waste decomposer Trinetra, made from microbial consortia and enzymes. Trinetra is for all small and marginal farmers who are suffering from degrading land or who resort to crop residue burning due to problems in land preparation or decomposing farm waste.

Category

Food and Agriculture

Industry, Innovation Area

Organic Agriculture, New generation Waste decomposer.

Patent/IPR

Green Cross Trinetra – Trademark reg.

Startup Registration Information

Registered with DPIIT, Reg No: DIPP43436

SDG Goals



Competitive Advantage

Trinetra application is simple as compared to other decomposers. Its fast in action with low cost. Time taken for manure preparation is as low as 30-45 days with very less cost. Trinetra can be applied for farm residue burning prevention, farm yard manure preparation, land reclamation & reviving soil microflora, zero-budget natural farming etc. The decomposed manure from Trinetra is rich in carbon and other micro nutrients that is used as a fertilizer for the succeeding crop.

Market Penetration

The company has already generated Rs 91 lakhs in revenue through its dealer network in Gujarat. The company will be now expanding to online channels and B2B / Govt. sales

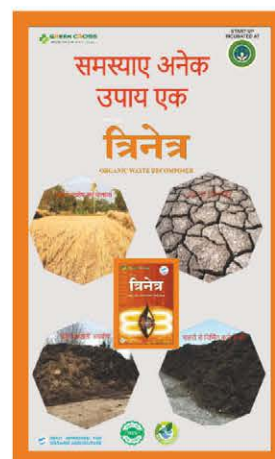

Trinetra: multipurpose waste decomposer

Key Clientele

- Farmers & food factories
- Government bodies providing subsidy for organic farming

Growth Plans

- POC validation from reputed ICAR bodies for further growth (DMAPR)
- After fund raising, scaling up of sales to 2000 MT in next 2-3 years. The estimated revenue will be 170 crores
- Carbon credit capturing (additional revenue model)
- Green funding for project expansion

About the Company

Green Cross Agritech is a bootstrapped DMAPR incubated startup based at Ahmedabad Gujarat aiming to provide approved organic agri inputs for framers at low cost.

About the Founder

Jayesh Ranninga, an M.Sc. in Agri-Plant Pathology, 2003 from Junagadh Agri University with 13 years of experience in agrochemical marketing and development.

Contact Information

✉ Jayesh@greencrossagritech.com

☎ +91 99099039494

🌐 www.greencrossagritech.com

🌐 [jayesh-ranninga-44a9b31b8](https://www.linkedin.com/company/jayesh-ranninga-44a9b31b8)



Healventure Biosciences, New Delhi

Innovation: Insect Protein based Poultry & Aquaculture Feed

Product Information

“Buggy” is an Insect protein based aquaculture and poultry feed which is rich in antimicrobial peptides to enhance immunity and survival rate of livestock animal. Unlike other animal or plant protein based feeds, Buggy doesn't require any growth promoter or antibiotic as an additive.

Category

Food and Agriculture

Industry, Innovation Area

Agri- Biotech

Patent/IPR

Patent Application No: 202011010000

Startup Registration Information

Registered with DPIIT, Reg No: DIPP54795

SDG Goals



Competitive Advantage

Healventure utilises organic waste to rear insects and are also working on a zero waste policy. Through their patent-pending technology, they are utilizing all by-products produced in bioconversion. This is helping to reduce expenses on antibiotics and growth promoters and also save feedcost by 20-30%. A single bio-convesion unit can mitigate upto 1500 tons of CO2 in next 5 years.

Market Penetration

The product is at TRL 7. Prototype (Minimum Viable Product) ready. Currently working with early adopters in U.P. and Odisha.



Aquaculture feed for fish

Potential Customers

Poultry & Aquaculture farms.

Growth Plans

- Set up bioconversion unit with feed mills in U.P. East, M.P and Odisha
- Fund raising for further R&D and establishment of bioconversion units in other states

About the Company

Healventure Biosciences is a biotechnology start-up developing nature's solutions for chemical-free agriculture and replacing antibiotics from livestock farming.

About the Founder

- Dr. Sumit Saxena, 10+ years' experience in the healthcare industry
- Dr. Megha Saxena, Alumni of AIIMS New Delhi, former faculty at Government Medical College, expertise in antimicrobial peptides.

Contact Information

✉ healventurellp@gmail.com

☎ +91 8851513115

🌐 <https://www.linkedin.com/in/dr-sumit-saxena-a27861189/>



Oscillo Machines, Mysore

Innovation: Electric Farm Machinery for Small and Medium Farmers

Product Information

Oscillo machines has developed a new age electric farm machinery implements and tools for small and marginal farmers. Their products include:

1. Root washed paddy transplanter
2. Electric paddy weeder
3. Electric poultry raking machine
4. E-DSR (Direct Seeded Rice)

Category

Food and Agriculture

Industry, Innovation Area

Farm Machinery. Farm Mechanization

Patent/IPR

Patents applied and published in 2021

Startup Registration Information

Registered with DPIIT, Reg No: DIPP46783

SDG Goals



Competitive Advantage

The farm machines are operated by integrating the traditional practices, easy to adapt, affordable and require low maintenance. These machines are durable and lightweight for women farmers use and can be repaired locally.

Market Penetration

Electric weeder and poultry raking machines are commercially sold across the country. For transplanter and E-DSR, the company is validating with field trail partner in upcoming kharif season.

Growth Plans

- Completing piloting with field trail partner
- Marketing and production of 180 units per year
- Promoting through demo camps and expo's
- Certification from Central Farm Machinery Training and Testing Institute



SRI Single Row
Electric Paddy Weeder



Electric Polutry
Raking Machine

Potential Customers

- Small and marginal farmers
- CHC's, SHG's and FPO's

About the Company

Oscillo Machines tries to address the problem about adaptation mechanization for any crop cultivation. Keeping both traditional approach and modern technologies integrated in their products, the company tries to bring out complete solutions for the Indian farmers.

About the Founder

- a) Prajwal M, MSc. in Physics from University of Mysore.
- b) Shivanand S, M.Tech in Machine Design, VVCE Mysore.

Contact Information

- ✉ connect@oscillomachines.com
- ☎ +91 9901136899
- 🌐 www.oscillomachines.com



Pelican Thermogenics, Alappuzha

Innovation: Microwave based Systems for Dehydrating Food

Product Information

Pelican's MuMah (Multiple Magnatron Heating System) is a microwave based dehydration system with multiple low capacity magnetrons in a central rotating shaft. It does rapid dehydration of food, keeping it from decaying and also keeping the nutritional value intact. The present unit is a 3kW system capable to dry 100 kg in 4 hours.

Category

Food and Agriculture

Industry, Innovation Area

Industrial Machines, Energy Efficiency

Patent/IPR

Patented Technology in China & Australia.

Startup Registration Information

Registered with DPIIT, Reg No: DIPP54017

SDG Goals



Competitive Advantage

The MuMah system is affordable (60-70%), cheaper than present MW systems and with low-temperature drying (~60-65°C) using a vacuum. It is faster, modular, and scalable from 100 kg to 1000 kg / batch of drying. The patented technology is easy to operate and takes less space compared to other conventional and solar dryers.

Market Penetration

The product is at TRL 5. The company has completed its first working prototype of a 3kW system (100 kg). Testing & certifications are ongoing. Customer trials will begin soon.

Growth Plans

- Build MVP and conduct testing at the customer site
- Testing & certification
- Design for manufacturing units
- Set up a manufacturing unit for MuMah



Pelican's MuMah: Multiple Magnatron Heating System

Potential Customers

- Food processors
- Farmers
- Farmer cooperatives

About the Company

Pelican is building the most efficient heating system using microwave technology. Their heating system is going to be in every waste management system, agriculture industry and food industries.

About the Founder

- Dr. Priya, in Chemistry of Natural Products has 25 research papers & 11 International patents.
- Dr. Manoj, Ph.D. in Natural Products Chemistry, has experience in the process industry, organic agriculture & waste management.

Contact Information

✉ pelicanthermogenics@gmail.com

☎ +91- 9207120003

🌐 <https://www.pelicanthermogenics.com/>

🌐 <https://www.linkedin.com/in/priya-rao-95b9b410/>



Ruhvenile Biomedical, New Delhi

Innovation: Indigenous DCOMPOZ™ Formulation to Decompose Organic Stubble within 10-15 Days in Ambient Conditions.

Product Information

Organic waste can be decomposed effortlessly within 10-15 days by using the first-in-line indigenous Dcompoz™ solution. The organic material produced as a result of the process acts as a fertilizer and increases moisture content in the soil and promotes regenerative agriculture.

Category

Food and Agriculture

Industry, Innovation Area

Agriculture

Patent/IPR

Patented Technology in China & Australia.

Startup Registration Information

Registered with DPIIT, Reg No: DIPP29327

SDG Goals



Competitive Advantage

The indigenous DCOMPOZ™ solution decomposes paddy stubble, waste vegetables and other biomass within 10-15 days in open conditions and demonstrates a 10-15% increase in NPK, Carbon, and moisture content in the soil; promoting regenerative agriculture. This first-in-line product will also reduce GHG emission via stubble burning, increase crop production and improve soil health, reducing the need for fertilizers.

Market Penetration

The product is to be marketed through three verticals:

- B2G-Business to Government
- B2B-Business to Business
- B2C-Business to Consumer

Growth Plans

- It is intended for the product to be commercialised in the next 12 months



Ruhvenile's DCOMPOZ Solution

Potential Customers

- Farming Community of India
- Urban Municipalities

About the Company

Ruhvenile is a research and innovation driven Indian company in New Delhi. They have received several grants from Government of India including BIRAC grants, Agri-Uddan for field trials. The company currently has over 12 patents and 10 trademarks and is internationally recognised as a deep-tech pioneer by Hello Tomorrow, Paris, France.

About the Founder

Dr Rajkumar Halder, has over 22 years of experience in research from three continents in Chemistry, Chemical Biology and Drug Discovery from IIT - Kharagpur, University of Pais Vasco-Spain, Max - Planck Institute - Germany, The Scripps Research Institute, California, USA and pharmaceutical industrial experiences from Novartis (GNF), San Diego, USA.

Contact Information

✉ info@ruhvenile.com

☎ +91- 7838874123

🌐 <http://www.ruhvenile.com>

🌐 <https://www.linkedin.com/company/ruhvenile-biomedical/>



Sand Bird, Chennai

Innovation: Smart Electric Tiller for Farm Application

Product Information

Sand-Bird has developed a smart electric tiller - Magma, a semi-automated system that can be remotely controlled and also offers GPS-enabled tracking, swappable battery, and retrofittable Agri- attachments. The 10kW version has a run-time of 4hrs with a remote operation range of 2km and a maximum speed of 15 kmph.

Category

Food and Agriculture

Industry, Innovation Area

Electric Vehicle, Agri-Equipments, Automotive Drivetrain

Patent/IPR

Design Patent filed in 2019. Yet to be granted.

Startup Registration Information

Registered with DPIIT, Reg No: DIPP56686

SDG Goals



Competitive Advantage

Magma offers 2x higher power and torque than conventional tillers. It reduces the operational cost by 10x and 3x lower lifetime expense for a rental agency. It also reduces operational cost by 25%. The rental model makes this product affordable for smallholder farmers. The Electric tiller has the potential to reduce 60 Mnt Co2 in next 5 years.



MAGMA: Smart electric tiller

Market Penetration

The product is at TRL 6. They are currently conducting pilots of their 3rd prototype with FPCs, rental agencies. They have LOIs from FPCs interested in buying the product.

Potential Customers

- Large farmers
- Machinery Rental Agencies

Growth Plans

- Certification done
- Sell 8000 units and reach out to 5 lakhs farmers
- Upgrade to a fully autonomous vehicle by 2026

About the Company

SandBird is a tech organization to analyze problems, design and develop new products for agriculture and farm mechanization units.

About the Founder

- a) S. Bala Surya comes with a farming background with 4 patents in product development with a passion to interact with farmers to solve their problems.
- b) Ajith Kannan, B.E. Mechanical Engineer with 3+ years of experience in off-road vehicles and bikes product development.

Contact Information

✉ sandbird.rd@gmail.com

☎ +91- 7550126088

🌐 <http://sandbird.in/> <https://>

🌐 www.linkedin.com/in/ajith-kanna-n-r-352b04134/detail/contact-info/



SapTKrishi Scientific, Kanpur

Innovation: Micro-Climate based Transportable Storage Solutions for Fruits & Vegetables

Product Information

SapTKrishi has developed a Preservator/ Sabjikothi that is a wheel mountable storage for transportation of fresh fruits and vegetables. It is a cost-effective, microclimate-based, portable storage that extends the shelf-life and preserves the freshness of fruits and vegetables anywhere between 5 to 30 days. It requires 20 watts of power and 1 litre of water every day to store up to 300 kg of fruits and vegetables.

Startup Registration Information

Registered with DPIIT, Reg No: DIPP35516

SDG Goals



Competitive Advantage

- First-mover advantage
- An alternative solution to this product can be small cold-storage units but they require high installation and maintenance costs
- Sabjikothi/ Preservator is a cost-effective, high-tech, and eco-friendly solution

Market Penetration

Minimum Viable Product tested, third-party validation completed and pilot ongoing at Bhagalpur Bihar. Partnering up with structure of trusted NGOs, self-help groups, and micro finance institutions.

Category

Food and Agriculture

Industry, Innovation Area

Post – harvest Agriculture

Patent/IPR

N/A



Sabjikothi: wheel mountable storage solution

Potential Customers

- Small & medium farmers
- Vendors & traders in the agri-supply chain

Growth Plans

Raise venture capital for commercialization and setting up own manufacturing unit for production.

About the Company

SapTKrishi is a young agri-tech startup incubated at IIT Kanpur, with youth in decisive roles who are determined to work towards agricultural innovation and transformation of rural South-East Asia. It addresses the issue of the perishability of horticultural commodities and works on reducing food wastage.

About the Founder

- Nikky Jha: B.Tech in Electronics & Communications Engineering and M.Sc in Environmental Sciences
- Rashmi Jha: Biotechnologist

Contact Information

✉ saptkrishi@gmail.com

☎ +91-8826217394

🌐 <https://www.saptkrishi.com/>

🌐 <https://www.linkedin.com/company/saptkrishi/>



Satyukt Analytics, Bengaluru

Innovation: Satellite-based Crop Advisory Solutions at Farm Level

Product Information

Satyukt has developed a unique in-house built algorithm that combines multiple satellite data along with the big data analytics, machine language, and physical algorithms in order to provide dynamic crop advisory solutions at farm scale.

Category

Food and Agriculture

Industry, Innovation Area

Satellite Remote Sensing, Agriculture

Patent/IPR

N/A

Startup Registration Information

Registered with DPIIT, Reg No: DIPP27702

SDG Goals



Competitive Advantage

- Satellite data within 1 day
- Forecasts risks 1-2 weeks prior
- Analysis based on 100% coverage
- Crop classification at any level globally
- Remote monitoring of the field saves 70% of the time

Market Penetration

The product is at TRL 9. Product Mobile application “Sat2Farm”, and web application “MICRO Sensing” are ready for giving crop advisory to farmers as well as other stakeholders, government & research organisations.

Growth Plans

- Development of web and mobile applications
- Reach to 5,00,000 farmers by 2024
- Fundraising for commercialisation



Sat2Farm mobile application

Potential Customers

- Agri-input & agri-output companies
- Water resource
- Crop insurance

About the Company

Satyukt Analytics is a B2B Agritech company which uses its inhouse developed algorithms for processing data from multiple sources (multiple satellites, physical data) to provide farm level solutions to B2B stakeholders in agriculture through their unique platform.

About the Founder

- Dr. Sat Kumar Tomar, Ph.D. in water resource under Dept. of Civil Engineering from IISC Bangalore. 10+ years of experience in this field.
- Dr. Yukti Gill: Ph.D. from B.H.U. having 8+ years of experience.

Contact Information

✉ contact@satyukt.com

☎ +91-9986568525

🌐 <https://satyukt.com/>

🌐 <https://www.linkedin.com/company/satyukt/>



Tapah Mechatronics, Bengaluru

Innovation: Electric IR Dryer for Clean Drying of Agriculture Produce

Product Information

Tapah Mechatronics has developed an Infrared based dryer for drying of all types of agriculture produce without the GHG emissions that occur from burning agricultural husk via commercially available equipments.

Category

Food and Agriculture

Industry, Innovation Area

Dryer equipment for agri-PHM drying

Patent/IPR

Patent Application No: PCTIB2020089605 & 059606

Startup Registration Information

Registered with DPIIT, Reg No: DIPP90924

SDG Goals



Competitive Advantage

Innovative Clean-tech equipment with zero emissions unlike highly polluting contemporary dryers available in the market.

Market Penetration

Local and Global markets for existing and newer markets for agricultural drying -

- All types of grain like Paddy, Wheat, Maize, Lentils
- Dehydration of vegetables like Onion, Garlic, Ginger, etc.
- Spices like Turmeric, Chilly etc.

Growth Plans

The target is to achieve INR 5 Cr turnover within 2 years with a minimum year on year growth rate of 30%.

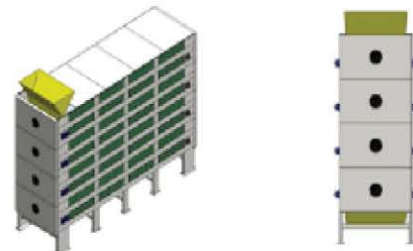

IR Dryer

Potential Customers

- Mill Owners
- Farmers Producers Organization (FPOs)
- Food Processing Industry
- Big Farmers (Local and Global)

About the Company

Agri-tech Certified start-up incorporated in 2018 and based out of Bengaluru, focused on Deep-tech development for clean disposal of agricultural waste.

About the Founder

Srinath GS has done his B.E. in Mechanical Engineering with 25+ years of rich industrial experience in sectors like Automotive, Aerospace, Medical Engineering, Oil & Gas and Industrial Engineering.

Contact Information

✉ info@tapah.in

☎ +91 91088 80142

🌐 <https://www.linkedin.com/in/tapah-mechatronics-019b78248/?originalSubdomain=in>

🌐 [com/in/tapah-mechatronics-019b78248/?originalSubdomain=in](https://www.linkedin.com/in/tapah-mechatronics-019b78248/?originalSubdomain=in)



Terracarb
Disruption through sustainable innovation

Terracarb, Coimbatore

Innovation: Graphene based Barrier Additive Solutions for Food Packaging

Product Information

Terracarb has developed a Graphene-based additive for high barrier packaging films manufactured using LDPE, PP and PLA. This is a sustainable alternative to reduce the use of plastic in multilayer packaging and could also be used to make biopolymers as competitive as multilayer packaging films.

Category

Food and Agriculture

Industry, Innovation Area

Nanotechnology

Patent/IPR

Patent Application No: 202041004340

Startup Registration Information

Registered with DPIIT, Reg No: DIPP42536

SDG Goals



Competitive Advantage

- Patent-pending Graphene production technology at 1/5 of the global production cost
- Utilization of high-volume production chemicals and standard industrial processes for production of Graphene
- Potential for scalable production of Graphene (5000 MT/ annum)
- Sustainable circular-economy driven production process

Market Penetration

The product is at TRL 7. Prototype (Minimum Viable Product) is ready. Pilot validation was done with an industrial customer based in Netherlands. Currently, the company is building a 1 Kg per day pilot plant.



Graphene based food packaging material

Potential Customers

- Multilayer packaging companies

Growth Plans

- Reach TRL 9 through large scale pilot deployment with industrial clients
- Validate barrier additive product with Polyplex
- Build 5 new use cases in the next 1 year

About the Company

Terracarb is an Indian deep-tech startup, working on manufacturing Graphene. By utilizing high volume production chemicals and conventional chemical processes, Terracarb strives to democratize the use of Graphene in paints, coatings and composites.

About the Founder

Mr. Solomon Jones, 4+ years of cross-functional experience in nanomaterials, 11+ international research publications, 5 commercial products developed using nanomaterials.

Contact Information

✉ solomon@terracarb.com

☎ +91 7093905101

🌐 <http://www.terracarb.com>

🌐 <https://www.linkedin.com/in/solomonjones2311/>

zerocircle **Zerocircle, Gurgaon**

Innovation: Sea Weed based Bioplastics for Food Packaging

Product Information

Zerocircle has developed a carbon-efficient and hyper compostable flexible packaging material from farmed sea weed. The packaging material slows down the fast ripening process of fresh food. The formulations are toxin-free and can even be consumed by animals and humans.

Startup Registration Information

Registered with DPIIT, Reg No: DIPP84277

SDG Goals



Competitive Advantage

Their products have low carbon footprint unlike other agri-based products that rely on feedstocks which competes with food.

Market Penetration

The company is presently testing their product prototype with a multinational consumer brand. Their target customers ranges from various FMCG companies to high end retail stores who are looking for affordable and sustainable packaging solutions.

Growth Plans

- Pilot scale-up of 500 kg of thin-films in Q2,2022
- Complete food safety compliances and receive relevant certification in Q3 and Q4, 2022

About the Company

Zerocircle creates low-carbon materials from restorative ocean-based resources. It aims to mitigate environmental impact at every stage of a single-use product's lifecycle.

About the Founder

Neha has worked for 15 years in the technology space scaling up tech-enabled businesses while working with companies like Google. The gap between automation and prevalent production methodologies pushed her to innovate with bio-materials.

Category

Food and Agriculture

Industry, Innovation Area

Clean Tech, Material Science, Waste and Environment

Patent/IPR

Provisional Patent filed



Packaging material based on sea weed

Potential Customers

- Global Food Companies like Nestle
- Packaging Industries
- Clothing brands

Contact Information

✉ info@zerocircle.in

☎ +91-9820073780

🌐 www.zerocircle.in

🌐 <https://www.linkedin.com/company/zerocircle>

INDUSTRIAL LOW GHG TECHNOLOGY



Innovation: Micro Gas Turbine for Heavy Vehicles

Product Information

Aerostrovilos has developed a single shaft micro gas turbine (MGT) with a lean direct injection burner which allows low turbine temperature. The system is modular (15kW – 100kW) and fuel agnostic that can run on any liquid fuel or gaseous fuel. The system can be retrofitted to any existing ICE trucks and act as an onboard power source for hybrid electric trucks.

Startup Registration Information

Registered with DPIIT., Reg No: DIPP12660

SDG Goals



Competitive Advantage

The MGT requires less expensive exhaust treatment systems due to low temperature. 25% economical savings for truck operators and improved life of up to 2x. Cleaner fuel with 75% less tailpipe carbon emissions will help leapfrog CAFE & BS-VI+ in advance.

Market Penetration

The product is at Technology Readiness Level (TRL) 5. Aerostrovilos completed its POC in December 2020. Currently, they are in the process of building their 50kW MGT to do pilots along with customers. They have already received an LOI to build a Turbine Electric Vehicle.

Growth Plans

- Build MVP and conduct testing at customer site
- Testing & certification of 20 units
- Road trials & product launch with 100 units
- Scale upto 5000 units

Category

Industrial Low Carbon GHG

Industry, Innovation Area

Automotive Drive-train, Industrial Machines

Patent/IPR

Patented Technology in India, US, EU & Australia. Indian Patent published in 2018.

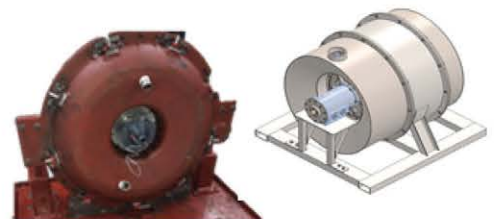

Micro Gas Turbine



Heavy truck with MGT Engine

Potential Customers

- Auto OEMs
- Truck fleet operators
- Logistics companies

About the Company

Aerostrovilos is an IIT-Madras based startup, manufacturing indigenous micro gas turbines for power generation.

About the Founder

- Rohit, an IIT-Madras alumnus 2016, from Aerospace Engineering, with prior experience working with Industrial jet engines.
- Pradeep, BE.Mech Engineering, and 10 yrs experience in operations, sales & supply chain, in manufacturing business and operations.

Contact Information

✉ rohit@aerostrovilos.com

☎ +91- 9600067714

🌐 <http://www.aerostrovilos.com/>

🌐 <https://www.linkedin.com/in/rohit-grover-9a895160/>

Innovation: Energy Efficient Aluminium Melting Furnaces

Product Information

AL-THERMOS is an aluminium molten metal holding furnace which holds the molten aluminium at 680°C in the die casting process where metal temperature plays an important role. The USP of AL-THERMOS is that it consumes 75% less power and requires zero to low maintenance.

Category

Industrial Low Carbon GHG

Industry, Innovation Area

Industrial Efficiency

Patent/IPR

In patent filing process

Company Registration Information

CIN Number: U27320PN2004PTC018814

SDG Goals



Competitive Advantage

The major competitors manufacture regular crucible type holding furnace which consumes 72 KW/Hr to hold 1ton molten aluminium, while AL-THERMOS consumes only 15 kW/hr to hold the same quantity. Also, the regular furnaces have a huge maintenance cost, while AL-THERMOS is maintenance-free.

Market Penetration

The product is at TRL 7. Product is in the manufacturing stage. It will be demonstrated and compared to the existing baseline products soon.

Growth Plans

- Set up a dedicated manufacturing line for the production of AL-THERMOS
- Replacing the existing holding furnaces with AL-THERMOS



Heat Treatment Furnace

Potential Customers

- Aluminium processing industries
- Aluminium die casting foundries

About the Company

AFECO HEATING SYSTEM manufacturers heat treatment furnaces, melting furnaces, drying ovens, systems required in hot material handling up to 1200°C. All the furnace designing and controlling software development activities are done in-house at AFECO.

About the Founder

Mr. Prakash Maladkar has a vast 30 years of experience in the Aluminium processing field and furnace manufacturing.

Contact Information

✉ maladkarshivranjani@gmail.com

☎ +91-9371634910

🌐 <http://www.afecoheating.com>

🌐 <https://in.linkedin.com/in/prakash-maladkar-ab03aa15>

Innovation: 2-in-1 Solar Modules to Generate Electricity and Hot Water

Product Information

2-in-1 solar modules which generate both electricity and hot water simultaneously as compared to a standard solar PV module of the same size. The company provides multiple systems from 3 kW-500 litres to 100 kW-20,000 litres per day systems for different customer segments.

Category

Industrial Low Carbon GHG

Industry, Innovation Area

Commercial and Industrial Segments

Patent/IPR

Patent Application No(s):
201941010297, 201941010296

Company Registration Information

CIN Number: U27320PN2004PTC018814

SDG Goals



Competitive Advantage

- Saves rooftop space
- Double the energy from same available rooftop space
- 25 years design life and 20-year warranty.
- 3x more life compared to an ordinary hot water system
- 66% lower maintenance costs.
- Shorter payback period and better ROI

Market Penetration

The product was successfully launched in the market in 2019 after prototype testing and pilot projects executed in 6 Indian states.

Growth Plans

- Fund raising for scaling up and new market entry
- Expansion through energy as a service (EaaS) model
- Establish a third-party reseller network through white labelling

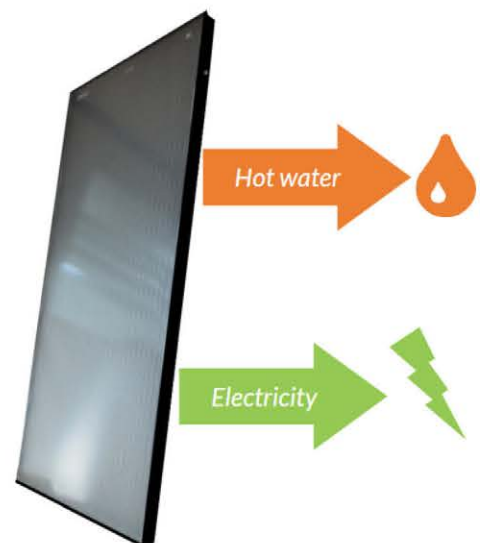

India's first 2-in-1 Solar Panel

Potential Customers

- Hotels
- Railways
- Real Estate

About the Company

Birds Eye Energy is an innovation-based energy company that is disrupting the rooftop solar industry with indigenous, first of its kind, patented, 2-in-1 solar technology (PV-T solar technology).

About the Founder

- Praneeth Pillarisetti, B.Tech (IIT Madras) and MS in Renewable Energy (Univ. of Florida) with 8+ years of R&D experience in Cummins, USA
- Harshavardhan, B.Tech (IIT Madras) and MBA (IIM Ahmedabad) with 8+ years experience with TATA Group (TAS).

Contact Information

✉ harsha@birdseyeenergy.in

☎ +91-9830936464

🌐 <http://www.birdseyeenergy.in/>

🌐 <https://www.linkedin.com/in/birds-eye-4281a3206/>

Innovation: Vortex based Small Hydropower Generation Module for Clean Energy

Product Information

BluPower Hydro incorporates the concept of biomimicry in the form of low-head for strategically-sited structures proven to restore watershed and ecology. Their Vortex Hydro-Engine turbine uses innovative and adaptive civil work which ensures safe upstream and downstream fish passage and has low environmental impact.

Category

Industrial Low Carbon GHG

Industry, Innovation Area

Hydro-Power Generation, Energy Recovery

Patent/IPR

Application and Design No. 326647-001

Startup Registration Information

Registered with DPIIT, Reg No: DIPP61015

SDG Goals



Competitive Advantage

- Modular product: Innovatively designed system bio-mimicking natural flow of vortex, improved through Computational Fluid Dynamics (CFD) analysis
- The Micro-Hydro Design operates on a patented research.

Market Penetration

Blu Power is trying to cater to its market through:

- Government, Private entities, NGOs to get connected with more potential customers
- Thermal Power Plants and Steel Plants to utilize the product within their existing water lines for potential energy recovery
- Tourism industry for applications in natural waterfalls

Growth Plans

- Incentivize corporations to improve their green ratings through the innovation
- Development of Women-led micro-utilities focused on decentralised renewable microgrid creation for a robust carbon negative energy infrastructure by 2050.

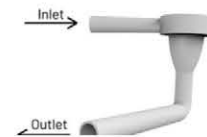
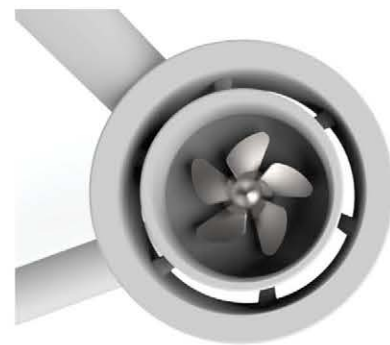

VortexHydro-Engine turbine

Potential Customers

- Thermal Power plants, STPs, etc.
- Irrigation Canals, Industrial Plantations, etc.
- Independent Project Developers focusing on decentralized clean energy infrastructure
- Government RE Projects

About the Company

The company is developing decentralised micro-grids through cost-effective, reliable, sustainable, autonomous hydroelectric solution combining innovative hardware and AI while empowering carbon negative economies.

About the Founder

Santanu has done B.Tech in Power Engineering from NPTI(ER) Durgapur. He has first hand awareness about the multitude of problems being faced in the Power Industry and the extreme need to rapidly transition from conventional to renewables.

Contact Information

✉ blupowerhydro@gmail.com

☎ +91 90510 77183

🌐 www.blupower.in

🌐 <https://www.linkedin.com/company/blupowerhydro>

Innovation: Smart Furnace Burners that Optimize Air Fuel Ratio for Complete Combustion

Product Information

BnG's oil and gas-fired furnace burners include fuel injection systems that help mix fuel and air more effectively thereby requiring lesser excess air for complete combustion.

Startup Registration Information

Registered with DPIIT. Reg No: DIPP29309

SDG Goals



Competitive Advantage

The furnace burners employ liquid fuel atomization techniques to spray liquid droplets that are up to 4 times smaller in diameter, thereby enabling better fuel-air mixing and more efficient combustion. The oxygen analyzers are at least 1/3rd the cost of imported gas analyzers, thereby reducing the payback time. The burners, AFR controllers, and oxygen analyzers used together deliver up to 10% better furnace efficiency.

Market Penetration

The company is currently conducting pilots with Hindalco and has developed India's first in-situ oxygen analyzer for flu-gases for natural gas and coal-fired boilers of Cipla and Raymond.

Growth Plans

- To complete pilot testing of 20 MW burner at Hindalco by June 2022
- To complete testing of air-fuel control system at Indian Naval ship boilers by August 2022
- To complete CE and ATEX certification of O2 analyzer by the end of 2023

Category

Industrial Low Carbon GHG

Industry, Innovation Area

Energy efficiency in boilers, furnaces, process heaters

Patent/IPR

3 product patents pending in India

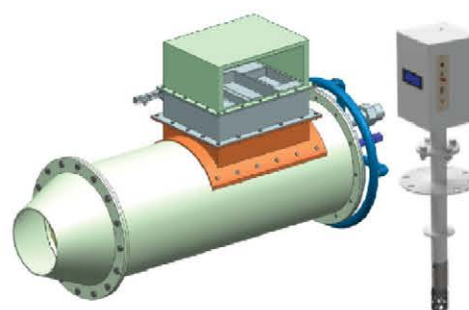

Furnace burner

Potential Customers

- Manufacturers of furnaces, boilers kilns, etc.
- Furnace end-users such as power plants and manufacturing mills for metals, glass, ceramics, refractory materials, cement, petroleum products, chemicals and fertilizers

About the Company

BnG Spray Solutions is a Bengaluru based startup that builds combustion and control systems for industrial furnaces with the aim of making them more energy efficient and smart, reducing GHG emissions and the capita cost associated with it.

About the Founder

Arindam Ghatak is a mechanical engineer from IIT-KGP and MS from the Ohio State University, with over 15 years of industry experience including 10 years in upstream oil and gas industry in Houston, Texas.

Contact Information

- ✉ aghatak@bngspraysolutions.com
- ☎ +91 91139 97209
- 🌐 <http://bngspraysolutions.com/>
- 🌐 <https://www.linkedin.com/company/bng-spray-solutions>

Innovation: CO₂ Capture Technology for Small- and Large-Scale Emitters

Product Information

eGreen has developed a biological and chemical absorption System for CO₂ capture from process emissions. This enables organizations to reduce their carbon footprint, earn monetizable carbon credits and derive useful by-products from captured CO₂ like fuel and fertilizers.

Startup Registration Information

UDYAM Registration No. UDYAM-TN-04-0030976

SDG Goals



Competitive Advantage

eGreen has deployed a demonstration plant for Biological Absorption System at Coal Thermal Power Plant in India. eGreen's Chemical Absorption System is at TRL-4 with experimentations being conducted at IIT-Madras.

Market Penetration

- For small scale CO₂ emitter: eGreen is looking for process to convert algal matter to biofuel/fertilizers
- For large scale CO₂ emitters: eGreen is looking to setup demonstration plants to showcase the capture technology

Growth Plans

- Development and utilization of algal matter from Biological Absorption system in form of biofuel or fertilizer
- Reduction of energy demand of Chemical Absorption System
- Filing Patent on Experimented Chemical Concoction to be used in CO₂ capture process

About the Company

eGreen Compliance Consultants (OPC) is incorporated in 2018 to provide high-end environmental consultancy service along with R&D activities. eGreen has rendered services to several International Companies like World Bank, Aqualogus (Spain), Abu Dhabi International Airport, L&T UAE and ACC

About the Founder

N.Srinivasa Prabhu, has a Masters degree in Environmental Engineering from Carnegie Mellon University (USA) with more than five years of experience in the field of air quality, climate change and waste management.

Category

Industrial Low Carbon GHG

Industry, Innovation Area

Low Carbon Technology – CO₂ Capture Systems

Patent/IPR

Nil

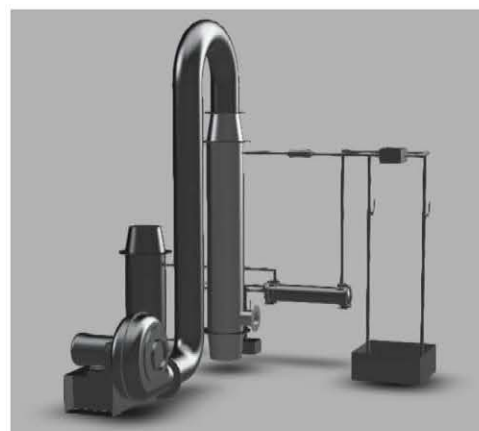

Amine System Render



Bio-Reactor

Potential Customers

- Small scale CO₂ emitters like kilns captive power plants, etc.
- Large scale CO₂ emitters like Thermal Power Plants, Cement Industry, Steel Industry, etc.

Contact Information

✉ info@egreen.org.in

☎ 9489588922

🌐 www.egreen.org.in

Innovation: Conversion of Unsegregated Solid Waste into Biofuel and Biomass Briquettes

Product Information

Industrial biofuel & biochar briquettes are made out of unrecyclable paper waste through the thermocracking process. Climate-conscious products Envofuel and Envobriq made out of waste used for heating applications.

Category

Industrial Low Carbon GHG

Industry, Innovation Area

Biofuels, Biomass Briquettes, Renewable Energy

Patent/IPR

5 Patents Applied

Startup Registration Information

Registered with DPIIT. Reg No: DIPP84168

SDG Goals



Competitive Advantage

Climate-conscious products with better technical parameters; competitive rates; patented unique technology; high processing capacity; easy availability; smart envoPROTECT App.



Envofuel and Envobriq

Market Penetration

The product is at TRL 7. Pilot plant setup is near Pune in a recycled paper mill premises.

Potential Customers

- Industries using boilers and furnaces & coal
- Agricultural industries

Growth Plans

- Key partnerships with paper mills
- Strong customer base
- Aim to install 80+ plants by 2028

About the Company

EnvoProtect is a solid waste management startup based in Pune providing the most sustainable solution for processing the plastic waste emerging out of recycled paper mills which is otherwise dumped or burned and converting it to climate-conscious products made out of waste that can be used for heating applications .

Contact Information

✉ info@envoprotect.co

☎ 9284164437

🌐 <https://envoprotect.co/>

🌐 <https://www.linkedin.com/in/karishma-shah-670150196/>

About the Founder

Karishma Shah, CEO & Co-founder, Computer Engineering, MIT Pune; Msc (EBM) University of Warwick, UK.

Exposome Exposome, Mumbai

Innovation: **Regenerable and Efficient Molecular Filters for capturing Air Emissions and Waste Water Treatment**

Product Information

Exposome has two patented product:

1. PurSafe™ - Molecular Gas Filtration Media:

Efficient, reusable and high quality media and filter capable of removing industrial scale CO₂ and corrosive gases as well as odors, volatiles, VOC's and PM 2.5.

2. PureCODE™ - Industrial Wastewater Molecular Filtration Media:

Easy to deploy low cost customizable media designed to remove selective molecules from effluent streams like persistent organics, eliminating the cumbersome processes implemented at the ETP's, while reducing cost by upto 40%.

Category

Industrial Low Carbon GHG

Industry, Innovation Area

Regenerable Molecular Filtration Medias for abating CO₂ & Corrosive Gases

Patent/IPR

7 IP's Filed- Patent Pending

Startup Registration Information

Registered with DPIIT. Reg No: DIPP72585

SDG Goals



Competitive Advantage

- Indigenous Regenerable Advance Technology which is efficient and cost effective
- Their products can help customers meet their Central Pollution Control Board (CPCB) emission and effluents discharge norms

Market Penetration

The company aims to target Oil & Gas Refineries, Textile Manufacturing & Processing Units, Food & Beverage Industries, Paint, Pigment and Dyes Industries, Semiconductor & Electroplating Industries.

Growth Plans

- Cumulative effort with service partners to pilot at the leading Industries
- Providing cost effective solutions as per the industry problem statements and help meet pollution norms



PureCODE™

Potential Customers

- Oil & Gas Refineries
- Chemical Manufacturing Industries
- Textile Manufacturing & Processing Industries
- Microelectronics Manufacturers
- Commercial Builders and Consultants

About the Company

Exposome is a material science start-up focused on inventing and manufacturing reusable media and filters, that helps mitigating air pollution, treating effluents and meeting industrial compliance requirements.

About the Founder

Dr Prerna Goradia – Material & Coatings Expert – CTO
Dr Amit Goradia – Technology Director, Scale-Up & Data/ Sensors Expert
Ashish Daga- Lead Generator and COO

Contact Information

✉ info@exposome.in

☎ 9769664015

🌐 www.exposome.in



Grassroots Energy, Bengaluru

Innovation: Low Cost Distributed Efficient Biogas Generation & Storage

Product Information

Grassroots Energy has developed a low-cost modular decentralized biogas production process. Additionally, the slurry is converted to transportable value-added products using proprietary technology.

Category

Industrial Low Carbon GHG

Industry, Innovation Area

Industrial, Waste to Energy

Patent/IPR

Patent Application No (s):

Startup Registration Information

Registered with DPIIT. Reg No: DIPP9053

SDG Goals



Competitive Advantage

The upgradation technology from Grassroots is modular, distributed and closer to the waste generation site. The system is 30% lower in CAPEX and 50% lower in OPEX per cubic meter of operation compared to its alternatives. Their innovative absorbed gas cylinder storage helps store gas at up to 3x lower pressure thus reducing the overall transportation cost.



Bio-Methane enrichment and storage

Market Penetration

The product is at TRL 7. Prototype (Minimum Viable Product) ready. Pilot validation is done with industrial customers. Currently working with mini-grids in Bihar and industries in Karnataka.

Potential Customers

- Small and marginal farmers
- Local communities

Growth Plans

- Set up 1000 distributed biomethane plants over the next 5 years
- To serve biomethane as a replacement for fossil fuels to industries

About the Company

Grassroots Energy Technologies (I) Pvt Ltd is involved in setting up distributed biomethane plants in areas without gas grids as well as manufacturing high-quality organic agri-inputs as a by-product of its operations.

About the Founder

- a) Mateen Abdul, MBA Babson, 16+ yrs in distributed energy, cleantech & automobiles
- b) Pradeep Podal, M.Tech Energy, IITB, 12+ years experience in renewable energy & IT

Contact Information

✉ mateen@grassrootsenergy.co

☎ +91-9916298362

🌐 www.grassrootsenergy.co

🌐 <https://in.linkedin.com/company/grassrootsenergy>



Torus Robotics, Chennai

Innovation: Compact & Lightweight Axial Flux Motor for Vehicles

Product Information

Torus Robotics has indigenously designed and developed one of the world's most compact & lightweight axial flux motors. These motors are scalable from 0.25 kW to 500 kW (12V to 500V). These motors provide greater reliability, high efficiency (>95%) and high power density (3kg for 3kW).

Category

Industrial Low Carbon GHG

Industry, Innovation Area

Industrial Automotives

Patent/IPR

N/A

Startup Registration Information

Registered with DPIIT, Reg No: DIPP51485

SDG Goals



Competitive Advantage

Being an indigenous and efficient solution, it provides upto 50% reduction in total cost of ownership, 15% increase in EV performance, and up to 2x increase in range due to better form factor and reduced weight. It has the potential to mitigate 500 MntCO2 considering 10,000 units sold.

Market Penetration

Torus is presently at TRL level 5 with a functional prototype. The next step is to conduct field testing with customers. The company has received interest from various Vehicle OEMs for pilot procurement and deployment.



Electric powertrain and Unmanned ground vehicle

Growth Plans

- File for patents
- Complete testing & certification
- Sale of motors and controller units
- Set up an assembly unit for direct sale of motors

Potential Customers

- Vehicle OEMs
- Industries and defence projects
- Independent power producers and agriculture sectors.

About the Company

Torus Robotics indigenously designs and manufactures, efficient electrical drives for electric vehicles and other industrial and commercial applications.

About the Founder

- M. Vignesh Director, Co-Founder, Business & Finance, B.Tech (Mechatronics), MBA.
- K. Abhith Vignesh Director, Co-Founder Technical and R&D, B.Tech (Mechatronics), MBA.

Contact Information

✉ taurus.defence@gmail.com

☎ +91-9884667059

🌐 www.torusrobotics.com

🌐 <https://in.linkedin.com/in/vigneshm94>



Ventragen, Jalgaon

Innovation: Mechanical Pulsed Power Transmission System for Harnessing Gravitational Energy

Product Information

Ventragen has developed a mechanical pulsed power transmission technology capable of harnessing gravitational energy during the power transmission process resulting in increased power output, which reduces the energy consumption of machines by upto 50%.

Startup Registration Information

Registered with DPIIT, Reg No: DIPP55822

SDG Goals



Competitive Advantage

A first of its kind, Ventragen has developed a mechanical system that is retrofittable, affordable, and can reduce power consumption by at least 30%. It provides a 20% reduction in capital expenditure and up to 40% reduction in operational expenditure. Potential to mitigate 1MT of CO2 in next 5 years.

Market Penetration

The product is at TRL 5. The company is piloting at its customer site to develop its minimum viable product. The company is also working with Small & micro-manufacturing industries in Maharashtra for pilot run.

Growth Plans

- Validate minimum viable product through pilot deployment
- Raise seed funding for product development
- Focus on R&D

Category

Industrial Low Carbon GHG

Industry, Innovation Area

Industrial Machines, Automotive Drivetrains

Patent/IPR

14+ National & 2 International patents filed.



Mono and dual harnesser

Potential Customers

SMEs (Equipment Manufacturing) with parallel operation of drives, EV-OEMs range extender.

About the Company

Ventragen focuses on the commercialization of pulsed power transmission systems for various industrial sectors and innovative affordable and highly efficient engineering solutions in the mechanical power transmission sector.

About the Founder

- Pankaj Attarde, B.E., Mechanical with 18 years of experience in sales and supply chain in MNCs.
- Saurabh Chaudhuri, B.E., Mechanical from North Maharashtra University.

Contact Information

✉ pankaj@ventragen.com

☎ +91- 9930298908

🌐 <https://ventragen.com/>

🌐 <https://www.linkedin.com/in/pankaj-attarde-b347b71b>

RESOURCE EFFICIENCY



Innovation: In-house Sustainable Technology to Convert Waste into Building Materials.

Product Information

WRICKS: Lightweight and damp-proof bricks made from 100% recycled waste material. Wricks are 40% stronger, 30% lightweight and 80% waterproof compared to traditional bricks. The product has been tested on all the standard parameters by NABL and ISO certified labs and has shown outstanding results in pilot demonstrations.

Category

Resource Efficiency

Industry, Innovation Area

Converting waste into value added building materials

Patent/IPR

1 Patent Pending

Startup Registration Information

Registered with DPIIT, Reg No: DIPP70495

SDG Goals



Competitive Advantage

- Damp proof, 30% lightweight (compared to conventional bricks), saves up to 20% brick work cost and is recyclable
- In-house Technology, up to 50% cost efficient and one day production time

Market Penetration

The company aims to target the green building sector of the country utilising government incentives on green buildings.

Growth Plans

- Product optimisation, building SOPs and pilots with potential customers.
- Achieve required test certifications and green Pro label
- Product validation and scaling into green building sector, targeting green developers and Architects in Bengaluru



standard brick replacement-WRICK



Pavement Tiles

Potential Customers

- Green Builders
- Green Building Architects
- Real Estate Developers

About the Company

Angirus is a Circular Economy start-up that makes lightweight and dampproof bricks using low-grade plastic waste and industrial waste using their innovative patent pending technology. The objective is to provide sustainable alternatives to the brick industry while solving waste management issues.

About the Founder

Kunjpreet Arora and Lokesh Puri are the co-founders from a civil engineering background with hands-on experience of the construction industry having previously worked with Udaipur Municipal Corporation, operating the municipality's C&D waste plant.

Contact Information

✉ kunjpreet@angirusind.com

☎ +91 8949008532

🌐 <https://www.angirusind.com/>

🌐 [linkedin.com/company/wricks](https://www.linkedin.com/company/wricks)



Aria Aerotech, Mumbai

Innovation: Use of Telematics to Enhance Fuel Efficiency of Transport Vehicles

Product Information

Aria Aerotech is focused on making transport vehicles more sustainable and the transport businesses more profitable. The company uses the power of telematics and data analytics to pinpoint the most cost-effective ways to achieve maximum fuel efficiency.

Category

Resource Efficiency

Industry, Innovation Area

Automotive, Vehicle Engineering

Patent/IPR

N/A

Startup Registration Information

Registered with DPIIT, Reg No: DIPP14823

SDG Goals

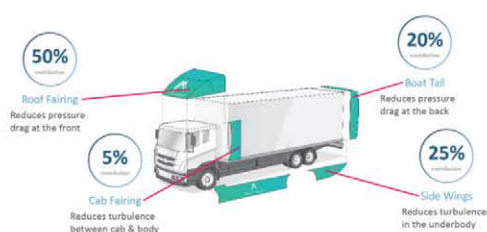

AeroTruck

Competitive Advantage

Commercial vehicles make up a small fraction of the vehicles on road, consuming the system's majority of petroleum products. By focussing on making the vehicles more fuel efficient, the dual aims of making more profit and reducing harmful emissions can be met.



Trucks equipped with AeroTruck kit

Market Penetration

The product is at Technology Readiness Level (TRL) 8. Prototype (Minimum Viable Product) is ready. The product has been tested with a few customers already.

Growth Plans

Modification of vehicle design to conduct operational training for stakeholders.

Potential Customers

- Large and medium truck fleets
- Logistic companies

About the Company

AEROTRUCK® is a copyrighted & patent-pending aftermarket Aero-kit for Indian trucks that can improve fuel efficiency by 7-12%. Implementing AEROTRUCK® on 25% of Indian heavy-duty trucks can save 1 billion liters of diesel consumption annually.

About the Founder

Pradeep Pandurangi, MSc in Aerospace Engineering, Technische Universiteit Delft, 2012- 2014.

Contact Information

✉ pradeep@aerotruck.in

☎ +91 8369313151

🌐 www.aerotruck.in

🌐 linkedin.com/in/pradeepvpandurangi



EcoOrbit AI Solutions, Hyderabad

Innovation: Automated Waste Segregation System

Product Information

EcoOrbit is building an automated robotic system that can identify and segregate dry waste, upto 1 tonnes per day from a moving conveyor. A customizable vision system identifies different materials based on requirements from Material Recovery Facilities (MRFs) thereby digitizing Waste Management.

Category

Resource Efficiency

Industry, Innovation Area

Scaling up waste segregation operations & procurement using Smart Automation.

Patent/IPR

N/A

Startup Registration Information

Registered with DPIIT, Reg No: DIPP106752

SDG Goals

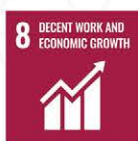

Competitive Advantage

- Low cost and easy installation solutions for faster scaling up of operations
- The monitoring tool offers Integration and intelligent insights across the operational value chain
- End to end analysis and optimization of the operations

Market Penetration

- Deployment of machine learning models and provide insights into material procurement & segregation operations
- Leverage trust gained using insights to deploy the robotic solutions
- Concentration on early adopters and Innovators for initial robot deployments
- Robot-as-a-Service model for mass adoption by target customers

Growth Plans

- Pilot the monitoring tools across multiple Material Recovery Facilities (MRFs) in and around Hyderabad
- Deployment of 50 units of Vision system hardware unit and deploy them in MRFs across South India
- Deployment of robotic waste segregation systems across 10 MRFs in the next year

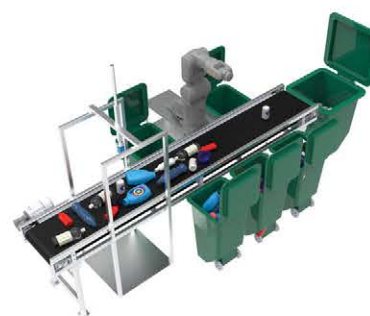

EcoOrbit Conveyor Solution

Potential Customers

- Dry Material Recovery Facilities
- Mixed waste segregation companies
- Recycling companies

About the Company

EcoOrbit Solutions is a Smart Automation Company which uses Robotics, AI, IoT and ML technologies to scale up waste segregation operations.

About the Founder

Abhishek Gorle, M.E. from BITS Pilani in Design Engineering. Prior to his entrepreneurial journey, he was working with TE Connectivity and NTT DATA GDS.

Contact Information

 abhishek.g@ecoorbitsolutions.com

 +91 7993695343

 <https://ecoorbitsolutions.com>

 <https://www.linkedin.com/in/abhishek-gorle-13b288167/>

Innovation: Use of Steel Waste to create Green Alloy Castings

Product Information

Green Trek recycles steel waste and converts it into various products of steel and alloy castings for heavy industries. Utilizing technology, these green steel products are manufactured using 0% fossil fuel to achieve a circular economy model thereby reducing GHG emissions from the steel industry.

Category

Resource Efficiency

Industry, Innovation Area

Resource Efficiency, Waste Management

Patent/IPR

Currently working on it.

Startup Registration Information

Registered with DPIIT, Reg No: DIPP84168

SDG Goals



Products from recycled steel waste

Competitive Advantage

Green Trek products have a higher level of purity, less expensive and higher durability.

Potential Customers

- Cement plants
- Stone crushers
- Power plants

Market Penetration

The product is at TRL 9. The company has validated its products and is currently in early revenue stage. It's target market is Himachal Pradesh, Jammu & Kashmir and Ladakh.

Growth Plans

- Reach production capacity of 200 MT/month
- Open unit in North East
- Penetrate into Canada & UK markets
- Diversify into other green technology areas

About the Company

Green Trek is an IIT-Mandi based startup that recycles steel waste and converts it into usable products for multifarious industries by utilizing technology where GHG's are reduced and a waste management process is put in place.

About the Founder

Sandeep has more than 8+ yrs experience in the foundry line. He oversees the manufacturing, R&D and operations part. Having worked abroad in MNC's he has a wide range of experience in HR & Administration.

Contact Information

 sandeep@greentrek.co

 +91- 7889480893

 www.greentrek.co

 <https://www.linkedin.com/in/green-trek-r-0303a01b0>



Himalayan Hemp, Kangra

Innovation: Wattle & Daub Hemp Hut without Cement, Concrete or Lime

Product Information

Himalayan Hemp has developed India's 1st wattle and daub hemp hut without using any cement, concrete or lime. They have a workshop model where they train people to build houses made of hemp.

Startup Registration Information

Registered with DPIIT, Reg No: DIPP52929

SDG Goals



Competitive Advantage

- Alternative and sustainable building material
- India's only hemp construction workshop
- Free from cement, concrete, and lime breathable walls
- Competitive cost (INR 1350 cubic ft) and less time-taking (30 days) excluding interiors
- Modifiable with flexible build methods

Market Penetration

The product is at TRL 5. The company has completed their first build project in Kullu, Himachal Pradesh in September, 2021 in the form of a workshop.

Growth Plans

- Extend our capacity to 12 workshops per year
- Conducting validity testing and certifications for all builds
- Enhance the interior design product range and reduce the carbon negativity by 30 tons in next 5 years
- Emerging as the top hemp construction company in the world

About the Company

Himalayan Hemp is a BIRAC, RABIRKVY and Nidhi-EIR supported social enterprise building on paving a pathway for the hemp community.

About the Founder

- Haneesh Katnawer, ED and CEO, BE(Production) with 7years of experience in project management, consulting and lean six sigma.
- Sonam Sodha, MD, MBA (IBM and IT) with 5 years experience in HR and project management.
- Shreyas Papanna, B. Arch (BMS School of Arch.)

Category

Resource Efficiency

Industry, Innovation Area

Construction and Training, Ecofriendly Buildings

Patent/IPR

Will be done after the testing and certification



Wattle & daub hemp hut

Potential Customers

- Architect students
- Engineering students, Eco-builders
- Healing center-owners

Contact Information

✉ hempslapcrew@gmail.com

☎ 8219655168,7090606151

🌐 www.himalayanhemp.in

🌐 <https://www.linkedin.com/company/77944060/>



Jivoule Biofuels, Hyderabad

Innovation: Transforming Organic/Biomass/Agricultural Waste into Compressed Biogas

Product Information

Jivoule Biofuels developed a new business model to transform organic/biomass/agri waste into compressed biogas (CBG) that can be utilized as a transport fuel to replace CNG and industrial fuel to replace natural gas.

Category

Resource Efficiency

Industry, Innovation Area

Renewable Energy, Business Model Adopting Digital Technologies

Patent/IPR

Will apply post the commercial production begins

Startup Registration Information

Registered with DPIIT, Reg No: DIPP69393

SDG Goals



Competitive Advantage

- New and improved business model that creates, captures and delivers value
- Digital technologies for operations and maintenance, reliability, yield improvement and quality

Market Penetration

- The company are about to sign a commercial agreement to supply 2.4 TPD of CBG from upcoming plant in Hyderabad
- Secured offtake guarantee of supply of CBG for 15 years
- Pitched solution to two large corporates

Growth Plans

- Setup 1st CBG plant in Hyderabad
- Expand model both to B2G and B2B
- Setup 10 CBG plants in next 3 years
- Build and develop market linkages of organic manure market with agritech startups

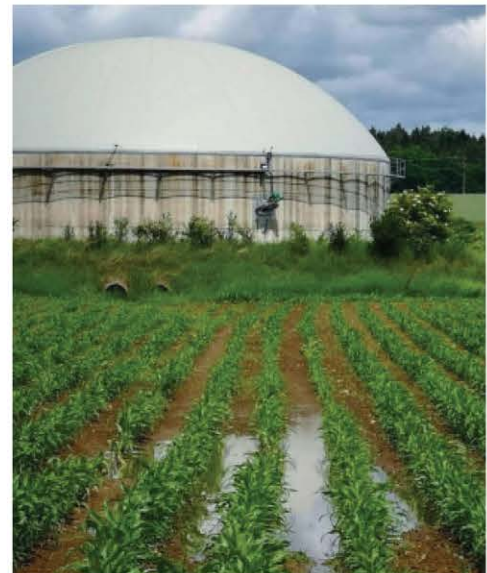

Compressed Biogas (CBG) Plant

Potential Customers

- PSUs

About the Company

Jivoule Biofuels is pioneering tech enabled circular economy by transforming organic/biomass/agri waste into biofuels.

About the Founder

- N Chandrasekhar has done masters in chemical engineering in USA and has wide skills and experience in manufacturing, project & quality anagement.
- R Koumudi has done B. tech in computer science and has deep experience in programming and ERP.

Contact Information

✉ chandrasekhar.nandigama@jivoule.com

☎ 8142909004

🌐 <https://www.jivoule.com>

🌐 <https://www.linkedin.com/in/chandrasekhar-nandigama/>



Malhari Projects, Ahmedabad

Innovation: Infrared Pyrolysis System to Eliminate Waste at source

Product Information

Malhari Projects has developed patented infrared pyrolysis technology which eliminates waste at the source of its generation and reduces the load on waste management channels from collection, transportation, segregation, compaction, bio-mining, trommel and land filling.

Category

Resource Efficiency

Industry, Innovation Area

Solid waste Management

Patent/IPR

Patent Application Number: 202221028740

Startup Registration Information

Registered with DPIIT, Reg No: DIPP79417

SDG Goals



Competitive Advantage

Elimination of waste at source leads to reducing waste handling channels, infrastructure, cost and increasing the efficiency of waste disposal.

Market Penetration

The company aims to perform POC with sectors generating bulk waste from industries across Textiles, Chemicals, Municipal, Bio medicals, Paper, Pharmaceuticals, etc.

Growth Plans

- To initiate with adopting a small scale land fill and eliminate the waste from the site as demonstration
- To showcase the efficiency of the technology in allied sectors to make production and sales plan work together



Waste to Air converter

Potential Customers

- Municipal Corporation, Smart Cities, Townships and Residential Projects
- Hospitals and healthcare groups, Maternity centres and Clinics
- Pharmaceutical, Chemical Companies and Industrial waste generators

About the Company

Malhari Projects is a waste disposal company, which helps bulk waste generators to eliminate waste at source and convert it to non toxic air.

About the Founder

Mihir Dixit, Vaibhav Patel and Dhruv Chauhan are the co founders from Gujarat Technological University, worked with major PSUs in the past. They have a combined experience of Design and Projects with Production and Quality control as well as Sales and Marketing.

Contact Information

✉ info@malhariprojects.com

☎ +91 8140222477

🌐 <http://malhariprojects.com/>



REVY-S, Vadodara

Innovation: Microbial Consortium for Waste Water Treatment and Biogas Generation

Product Information

REVY-S has formulated an innovative bacterial consortia that aids in effective treatment of waste water which enables improved operation and better performance of waste water treatment plants, and bioremediation of organic waste for improved biogas generation.

Category

Resource Efficiency

Industry, Innovation Area

Industrial, Biotechnology

Patent/IPR

Patent Application No(s): 201721040610 & 201921002371

Startup Registration Information

Registered with DPIIT, Reg No: DIPP8715

SDG Goals



Competitive Advantage

The company is treating waste water in an effective and economical way. India's first granulated sludge product with highest methanogenic content. Unlike other competitors, Revy-S provides 50% more biogas and 60% more savings along with up to 100% recovery of process water. Potential to mitigate up to 3000 Mnt CO2 in next 5 years.



Production Plant @ Revy Facility

Market Penetration

The product is at TRL 7. Prototype (Minimum Viable Product) ready. Pilot validation is done with industrial customers. Currently working with food & beverages industries of Gujarat for pre-commercial deployments.

Potential Customers

- Food & beverages industries
- Textile industries
- Biogas plant manufacturers.

Growth Plans

- Set up a large-scale manufacturing plant
- Reach TRL 9 through large scale pilot deployment with industrial clients
- Fund raising for commercialization

About the Company

REVY Environmental Solutions provides waste-water treatment and bio-methane production through anaerobic digestion (AD) process. They provide bio-cultures to enhance aeration in ETPs / STPs for industrial waste containing high phenol or TDS.

About the Founder

- Dr Vanita Prasad, Ph.D. in Biotechnology under Dept. of Biotechnology & CSIR, GOI.
- Rajneesh Prasad, 25+ years of experience in strategic planning, product

Contact Information

✉ rajneesh.prasad@revy.co.in

☎ +91-9824519652

🌐 <http://www.revy.co.in/>

🌐 <https://www.linkedin.com/in/rajneesh-prasad-29419312>

Innovation: Energy Savings in Pneumatic Applications

Product Information

Pneumatic economizer which can save return stroke compressed air (40%) in industrial automation and pneumatic machines. Maximum applicability is in cottage, food and other automated industries.

Category

Resource Efficiency

Industry, Innovation Area

Automation, Energy Efficiency

Patent/IPR

Patent Application No(s): 396324 (India)

Startup Registration Information

Registered with DPIIT, Reg No: DIPP65468

SDG Goals



Competitive Advantage

Operational energy cost reduction upto 40% from the time of installation.

Market Penetration

The company aims to establish direct partnerships with Industrial Automation Industries

Growth Plans

- Build equipment for small industries for measuring other industrial parameters.
- Industry partnerships with automation companies for product manufacturing and marketing



Pneumatic Economizer design



Pneumatic Economizer Prototype

Potential Customers

- Cottage Industries (textile manufacturers, disposable utensil manufacturers)
- Automated Industries with Pneumatic Systems
- Industrial Automation Companies

About the Company

Svakalpan is an Innovative company with the main goal is to generate IP around the solutions needed in various industries.

About the Founder

Anantha Narayana is the founder and CEO of Svakalpan. He has done Masters Degree in Mechanical Engineering from MNNIT, Allahabad. Anantha Has about 2 decades of experience in Product Development and maintenance in association with VOLVO.

Contact Information

✉ anantha.narayana@svakalpan.com

☎ +91-97389 69376

🌐 <http://svakalpan.com>



TGP Bioplastics, Satara

Innovation: Biodegradable Plastic Packaging Material

Product Information

TGP Bioplastics has developed indigenous, low-cost, low-emission biodegradable plastics for flexible packaging. The company is selling biodegradable plastic granules as raw material for packaging industries to manufacture carry bags, garbage bags etc. Currently Indian packaging manufacturers rely 100% on imported raw materials which are expensive due to high production costs. TGP's material is 20-25% cheaper than any other biodegradable material but with same quality and mechanical strength.

Category

Resource Efficiency

Industry, Innovation Area

Polymer Manufacturing, Chemicals.

Patent/IPR

Patent Application No: 201921041337

Company Registration Information

CIN Number: U25209PN2019PTC185482

SDG Goals



Competitive Advantage

- The production method has eliminated fermentative methods which saves production costs as well as time
- It is aided by a unique chemical composition that gives high-quality products at lower costs

Market Penetration

They are currently at TRL 7. Industrial iterations for manufacturing and cost-effective production are going on.

Growth Plans

- Due to lower pricing and indigenous manufacturing, many industries are interested in our product
- The company wishes to develop further in a profitable yet eco-friendly manner with CAGR of 15-21%



Biodegradable plastic packaging material

Potential Customers

Plastic packaging manufacturers for carry bags, garbage bags and industrial packaging.

About the Company

TGP Bioplastics develops and manufactures low cost starch-based biodegradable plastic blends having low carbon emissions. TGP wants to enable packaging manufacturers with compostable material as an alternative to conventional plastic.

About the Founder

Karan, Tejas and Indrajeet, co-founders of TGP, have been together on various projects since their college. After graduating as engineers in 2018-19, they decided to work full-time on bioplastics as their prime interest.

Contact Information

✉ office@tgpbio.com

☎ +91 9850522469

🌐 www.tgpbio.com

🌐 www.linkedin.com/company/tgpbio

URAVU Uravu Labs, Bengaluru

Innovation: Adsorption based Thermal Device to convert Air into Potable Water

Product Information

Uravu has developed EVA, an adsorption based thermal device which provides 100% renewable water from the air. Using a desiccant material and a heat source (solar/waste heat) at 80 °C. EVA can execute multiple cycles of adsorption & desorption to trap humidity from the air and turn it into high-quality renewable water.

Category

Resource Efficiency

Industry, Innovation Area

Potable Water, Industrial Water Conservation

Patent/IPR

1 complete patent application & 1 provisional patent filed. 4 more are in pipeline.

Startup Registration Information

Registered with DPIIT, Reg No: DIPP2686

SDG Goals



Competitive Advantage

The technology is heat source agnostic and works in all geographies (> 30% RH & GHI of 3kWh/m²/day). Inbuilt thermal storage with 80% capacity utilization. The technology is modular and scalable from 10 LPD to 1 MnLPD. The company claims to provide water between US\$ 0.02-0.04/litre at scale. Potential to save 14,000 tCO₂ in 5 years.

Market Penetration

The product is at TRL 5. Currently conducting paid pilots of their 5 LPD system with beverage companies to reach a minimum viable product (20 LPD). Their order book consists of contracts from other FMCG beverage manufacturers.

Growth Plans

- Develop modular products 20-250 LPD
- Build reference plants – 2000 LPD
- Set up manufacturing plants for core components
- Raise US\$ 2 Mn in next round



5 LPD prototype

Potential Customers

- Beverage industries
- Real estate
- Energy manufacturing companies

About the Company

Uravu Labs is developing technologies like solar powered atmospheric water generation and decentralised greywater treatment to accelerate the progress towards water sustainability.

About the Founder

- Swapnil Shrivastav, B. Arch from NIT, Calicut & has 4 yrs experience in product development, fundraising & partnership.
- Venkatesh RY, B. Arch, NIT Calicut has 3.5 yrs experience in design and development.

Contact Information

✉ swapnil@uravulabs.com

☎ +91- 9995698162

🌐 <http://www.uravulabs.com/>

🌐 <https://www.linkedin.com/in/swapnil-shrivastav-374867aa/>

STORAGE TECHNOLOGIES

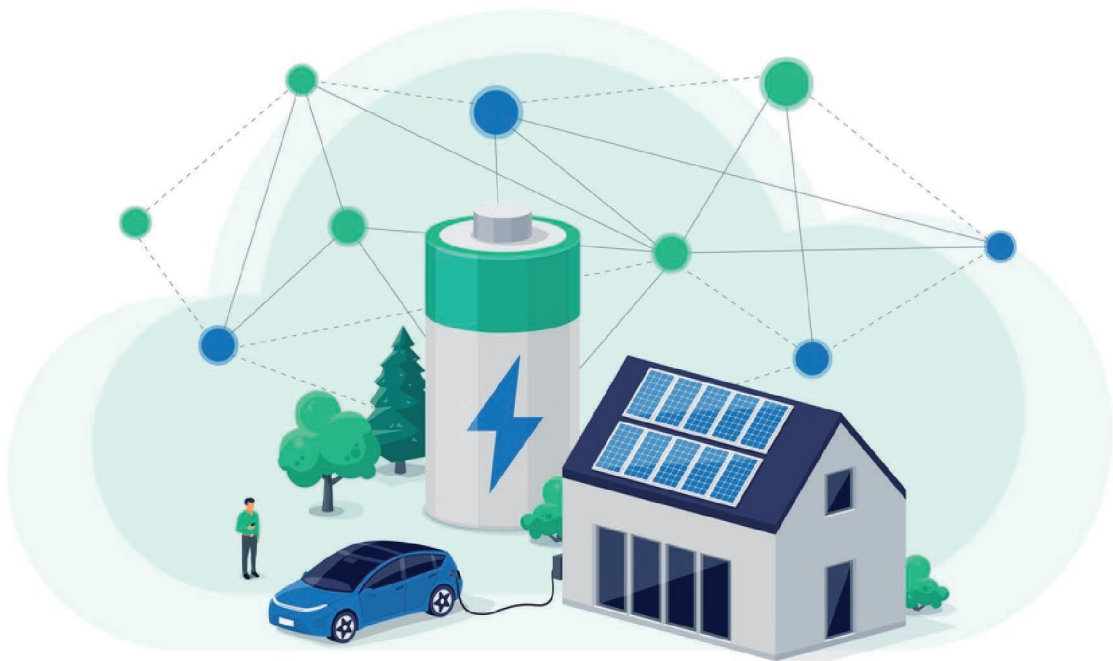

Innovation: Mesoporous Carbons for Enhancing Performance of Energy-Storage Devices

Product Information

Cancrie has developed premium quality novel mesoporous carbons made from bio-waste that delivers superior performance in energy storage devices. These carbons are energy efficient and easy to adopt.

Category

Storage Technologies

Industry, Innovation Area

Industrial, Energy Storage

Patent/IPR

Patent Application No: 202011040624

Company Registration Information

CIN NUMBER: U37200RJ2020PTC070052

SDG Goals



Competitive Advantage

Cancrie manufacture carbons to be used as an electrode material for electrical energy storage. The customers are battery manufacturers who want to improve their devices' life-cycle & charging time at a reasonable price. The product is made from renewable resources, consumes 89% lesser energy and delivers up to 125% higher energy density. Cancrie is the first company in India to produce this grade of carbon.



Mesoporous carbons made from bio-waste

Market Penetration

The product is at Technology Readiness Level (TRL) 6. The pilot scale setup is in Jaipur, India since 2019. The prototype (Minimum Viable Product) is ready. Ongoing pilot-scale validation with original battery manufacturer at industrial level in Delhi.

Potential Customers

- Lead-acid battery
- Lithium-ion battery
- Hybrid capacitors
- Super capacitors

Growth Plans

- Reach TRL 9 through small-scale production for B2B customers
- Penetration into the Li-ion battery market
- Production upto 1 tonne/day

About the Company

Cancrie converts biowaste into high-performing carbon for applications like energy storage devices, catalysis, water treatment and dye removal.

About the Founder

- Dr. Akshay Jain, Ph.D. Chemical Engineering, National University of Singapore, 9+ years of academic & industrial experience in R&D.
- Ms Mahi Singh, MS NTU, Singapore. 9+ years of experience in strategy.

Contact Information

- ✉ aks.che@gmail.com
- ☎ +65 9614 2205
- 🌐 <http://www.cancrie.co>
- 🌐 <https://www.linkedin.com/in/akshayjain4/>



MCS Cargar, Ahmedabad

Innovation: On-Demand Charge as a Service (CaaS) Platform and Mobile/Grid-free EV DC Fast Charger

Product Information

Cargar provides on-demand charge as a service for electric vehicles, DC fast charging anywhere-anytime. The charger can be hailed or scheduled using a mobile application to the EV location to charge an electric car in less than 45 minutes.

Category

Storage Technologies

Industry, Innovation Area

EV charging

Patent/IPR

5 IPR (4 trade mark & 1 Design), 2 WIP (Utility Patents)

Startup Registration Information

Registered with DPIIT, Reg. No: DIPP50799

SDG Goals



Competitive Advantage

On-demand mobile/grid-free/portable DC fast charge as a service eliminates set up and installation cost of infrastructure for charging system of four-wheelers. Intelligent, smart, modular & scalable technology with negligible downtime.



Cargar's Mobile Charging Station

Market Penetration

The company aims to target towards the drivers/users of EV ride hailing services.

Potential Customers

- EV Fleet Service Companies
- EV Users
- Institutions
- Gated Communities
- Malls

Growth Plans

Deployment of the service in Ahmedabad and Gandhinagar to serve EV ride hailing service drivers and later deploy the services for EV private users in gated communities/institutions/offices.

About the Company

Cargar is an on-demand charge as a service company and provides DC fast charging service anywhere-anytime.

Contact Information

- ✉ info@cargar.in
- ☎ +91-9662971994/9925024878
- 🌐 www.cargar.in
- 🌐 <https://www.linkedin.com/company/cargar/>

About the Founder

Raj Anupam has 8 years of experience in EV industry in technology development.
Kayavan has a Masters in Technology from New York University and 3 years of experience in Finance and Operations in a New York based start-up.

Innovation: Sustainable and Efficient Li-Ion Battery Recycling Solution

Product Information

MiniMines specializes in sustainably recycling end-of-life Li-ion batteries. Their proprietary HYBRID-HYDROMETALLURGY™ (HHM) process extracts rare elemental compounds like nickel, cobalt, lithium in their respective salts with pure copper and alumina with spherical graphite from mineral rich - Black Mass which can be directly utilized in the manufacturing of new Li-ion cells.

Category

Storage Technologies

Industry, Innovation Area

Lithium-ion batteries recycling

Patent/IPR

Patent Application No: 202111040571

Startup Registration Information

Registered with DPIIT, Reg. No: DIPP85959

SDG Goals



Competitive Advantage

Their revolutionary and scalable HYBRID HYDROMETALLURGY™ process will help in creating a safer, more customer-centric, and economically feasible solution, while also ensuring a sustainable supply of crucial and precious battery raw materials in supply chain.

Market Penetration

- Demonstrated lab scale recycling process to battery assembling and electric vehicle OEMs from Jaipur, Pune, and Bangalore
- Upscaled the processing unit from lab scale (2-5 kg/month) to the pilot plant which can process up to 50 kg/month of waste Li-ion batteries

Growth Plans

- Applied for a patent for the proprietary recycling process
- Trying to get hands on waste Li-ion battery supply sources

About the Company

A sustainable and efficient Li-Ion battery recycling clean-tech solution with its proprietary HHM process sustainably recovers precious battery-grade raw materials and reintroduces the extracted materials into the supply chain.

About the Founders

Anupam Kumar has R&D experience of more than four years. He handles business development, product development and client collaboration. Arvind Bhardwaj has more than six years of R&D experience in graphene nanotechnology and has worked in lead qualification, R&D management and product development.

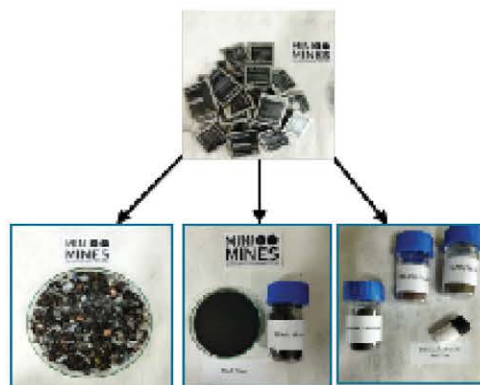

Minimines HYBRID-HYDROMETALLURGY™ Process

Potential Customers

- Li-ion Battery Manufacturers
- Steel and Copper Industries
- Grease and Lubricant Industries
- Ink and Paint Industries
- Pharmaceutical Industries

Contact Information

✉ info@m-mines.com

☎ +91-7903347483

🌐 <https://m-mines.com/>

🌐 <https://www.linkedin.com/company/mini-mines>



Offgrid Energy Labs, New Delhi

Innovation: Highly Energy Efficient Rechargeable Zinc based Batteries

Product Information

Offgrid has built a novel rechargeable zinc-based battery (ZincGel) that is 90% more efficient, sustainable and provides 2x returns relative to other rechargeable batteries (and provides a distinct advantage versus lithium-ion technology). ZincGel is targeting stationary & mobility applications with its two variants and has over 15 intellectual properties (IP) around chemistry, materials and design. ZincGel uses commonly available materials that are 100% sustainable & non-toxic, thus providing a sustainable energy storage alternative to the market.

Category

Storage Technologies

Industry, Innovation Area

Sustainable Batteries

Patent/IPR

4 patents filed (6 in the pipeline),
2 Trademarks granted 3 Trade Secrets

Startup Registration Information

Registered with DPIIT, Reg. No: DIPP19275

SDG Goals



ZincGel Battery cell by Offgrid

Competitive Advantage

The unique advantage of ZincGel is in its proprietary electrolyte that never evaporates and is non-flammable. ZincGel has identified several applications in which it can offer better role and safety. In such applications, ZincGel can even replace lithium-ion batteries and other zinc-based batteries.

Potential Customers

- Renewable industry
- Power utilities
- Low-power electric vehicles

Market Penetration

The product is at TRL 5 (validated in lab) and Offgrid has planned field trials with partners in both stationary and mobility applications.

Growth Plans

A robust plan for the next 18 months with field trials in stationary and mobility applications leading to commercialization by the end of year 2022.

About the Company

Offgrid is an IP-led, battery-tech company focusing on innovations in chemistry, materials and design to build efficient and sustainable batteries.

About the Founder

- Tejas Kusurkar, CEO, Ph.D., IIT Kanpur
- Brindan Tulachan, CTO, Ph.D., IIT Kanpur
- Rishi Srivastava, 25+ years in global deep-tech companies
- Ankur Agrawal, CFO, C.A.

Contact Information

✉ tsk@offgridenergylabs.com

☎ +91-800-444-3974

🌐 <https://www.offgridenergylabs.com>

🌐 <https://www.linkedin.com/company/offgrid-energy-labs/?viewAsMember=true>



Virya Batteries, Mumbai

Innovation: Ultra-safe Li-ion Cell and Battery Packs for 2 Wheelers

Product Information

Virya an IIT-Bombay incubated startup that has developed indigenous low-cost novel anode material and a specific electrolyte that does not allow formation of dendrite inside lithium-ion cells. Virya's patented chemistry allows the cells to operate at a high temperature preventing them from catching fire. Elimination of dendrite improves the life and performance of the battery as well. The company is targeting the 2 & 3 wheeler segment in India.

Category

Storage Technologies

Industry, Innovation Area

Sustainable batteries

Patent/IPR

Patent Application No.(s): 201821000200 & 201821048907

Startup Registration Information

Registered with DPIIT, Reg. No: DIPP30951

SDG Goals



Ultra safe lithium-ion battery

Competitive Advantage

- World's first ultra-safe dendrite free cells
- Lower early cell failures
- Local manufacturing, import substitution
- Competitive pricing

Market Penetration

The product is at TRL 7, MVP ready. Pilot production scale is completed. Industrial production scale expected to be completed by May 2022. Customer Field Trial expected to be completed by Jun 2022.

Growth Plans

- Pilot scale production of 500 kWh and test it across EV customers
- Set up an anode manufacturing unit

Potential Customers

- Electric 2 and 3-wheeler
- Swappable battery companies

About the Company

Virya batteries is a manufacturer of ultra-safe lithium-ion cells and packs providing highest quality, meeting the global standard. Startup from IIT Bombay, incubated at SINE. Patented Technology for increased safety of Li-ion cells technology.

About the Founder

- Sunil Mehta, B.Tech, IIT Bombay, MBA, Univ. of Minnesota, USA
- Prasit Kr. Dutta, M.Sc, Ph.D., IIT Bombay
- Prof. Sagar Mitra, Ph.D., IISc, Post Doc., France.

Contact Information

✉ info@viryabatteries.com

☎ +91-9820048263

🌐 <https://www.viryabatteries.com>

🌐 <https://www.linkedin.com/company/viryabatteries>

Stakeholders



The Global Environment Facility (GEF) was established on the eve of the 1992 Rio Earth Summit to help tackle our planet's most pressing environmental problems. Since then, the GEF has provided more than \$21.1 billion in grants and mobilized an additional \$114 billion in co-financing for more than 5,000 projects in 170 countries. Through its Small Grants Programme, the GEF has provided support to more than 25,000 civil society and community initiatives in 133 countries. It has a unique governing structure organized around an Assembly, the Council, the Secretariat, 18 Agencies, a Scientific and Technical Advisory Panel (STAP) and the Evaluation Office. It serves as a financial mechanism for several environmental conventions. The GEF finances project, programmes and initiatives that underpin the generation and exchange of knowledge around global environmental issues, facilitating the capture, synthesis, transfer and uptake of this knowledge within and beyond the GEF Partnership.



Bureau of Energy Efficiency (BEE) was set up by the Government of India on 1st March 2002 under the provision of the Energy Conservation Act, 2001. The mission of Bureau of Energy Efficiency is to assist in developing policies and strategies with a thrust on self-regulation and market principles with the primary objective of reducing energy intensity of the Indian economy within the overall framework of the Energy Conservation Act, 2001. It co-ordinates with designated consumers, designated agencies and other organizations and recognize, identify and utilize the existing resources and infrastructure, in performing the functions assigned to it under the Energy Conservation Act. The Major Promotional Functions of BEE is to create awareness and disseminate information on energy efficiency and conservation, arranging and organizing training of personnel and specialists in the techniques for efficient use of energy and its conservation, strengthening consultancy services in the field of energy conservation, promoting research and development, developing testing and certification procedures and promote testing facilities, facilitating implementation of pilot projects and demonstration projects, promoting use of energy efficient processes, equipment, devices and systems, promoting innovative financing of energy efficiency projects and giving financial assistance to institutions for promoting efficient use of energy and its conservation.

Stakeholders



The United Nations Industrial Development Organization (UNIDO) is a specialised agency of the United Nations that assists countries in economic and industrial development. It is headquartered at the UN Office in Vienna, Austria. As of April 2019, UNIDO comprises 170 member states, which together set the organization's policies, programmes, and principles through the biannual General Conference. The mission of the United Nations Industrial Development Organization, is to promote and accelerate inclusive and sustainable industrial development (ISID) in Member States. UNIDO's mandate is fully recognized in SDG-9, which calls to 'Build resilient infrastructure, promote inclusive and sustainable industrialization and foster innovation'. As a technical cooperation agency, it designs and implements programmes focused on its thematic priorities, which directly respond to global development priorities. Through these thematic priorities, UNIDO supports its developing country member states achieving the Sustainable Development Goals.

India is a founder Member of the UNIDO. It is both a recipient as well as a contributor to the programmes of UNIDO. The core elements of UNIDO's technical cooperation services in India are to implement its activities in harmony with national policy priorities and development strategies; to build strong and long-term partnerships with donors; to increase UNIDO's visibility; and to focus its assistance in a manner that addresses international development goals, especially the Sustainable Development Goals.



Sangam is a seed and early-stage venture fund that invests to improve access to sustainable energy and resource productivity solutions for the underserved in India that can lead to inclusive development and creation of communities that are resilient to climate change. Some of the top investments of Sangam includes Carbon Masters, Promethean Energy, Delectrik Systems, Smart Joules etc. Sangam was started by Karthik Chandrasekar to find a new model to provide early-stage support for climate change pioneers. Beyond investment we have AIC Sangam Innovation Foundation, India's first and only dedicated Clean Tech Incubator run by Sangam Capital Advisors in partnership with the Niti Aayog's Atal Innovation Mission Scheme. The Foundation was established in 2017 and currently runs 3 major acceleration programmes and an in-house incubation programme dedicated to fight climate change.

Thanks to Our Mentors



FLCTD

Promoting Innovation and Deployment of
Low Carbon Technologies

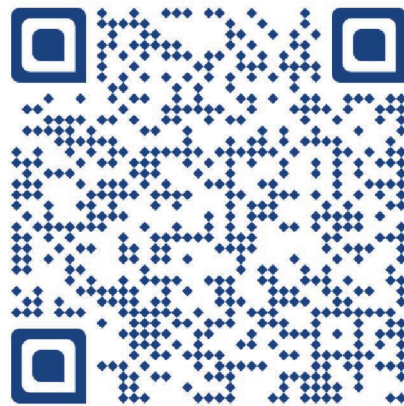

Implementation Partner



Outreach Partners



For further information, contact

Milind Deore (BEE)
m.deore@beenet.in

Sanjaya Shrestha (UNIDO HQ)
s.shrestha@unido.org

Sandeep Tandon (FLCTD PMU)
s.tandon@unido.org